



We have over 750 items in our catalog!

**FOR THE PBE AUTOMOTIVE AFTERMARKET,
THE SIGN INDUSTRY, PINSTRIPERS AND
BRUSH NEEDS IN BETWEEN**

ANDREW MACK & SON BRUSH CO.
216 East Chicago Street
Jonesville, Michigan 49250
Telephone: 517-849-9272

Fax: 517-849-2251
e-mail: info@mackbrush.com
orders@mackbrush.com
24-hour Answering Service
Office Hours: 9:00 a.m. - 4:30 p.m. M-F

"The Perfect Sales Display"

TO INCREASE YOUR
STRIPING BRUSH SALES
100%!!

NOW YOU CAN GET THOSE

Mack Brushes

OUT FROM BEHIND THE COUNTER
AND OUT OF THE DRAWERS AND
PROMOTE THEIR SALE TO
YOUR CUSTOMERS!



Actual Size:
16" Wide x 20" High

Advantages

1. It will give you a visible sales tool to sell the famous MACK STRIPING BRUSH.
2. It will attach to pegboard or mount on your display wall.
3. The display board hooks come with the display.
4. It will act as an Inventory Control (or a mini-salesman). When one size is gone, that part of the display will be empty and remind you to re-order. No more lost sales for lack of inventory. (The size that is all sold, plus our name, address, and telephone number will appear when your inventory is depleted.)

How Do I Obtain This Display?

1. If you presently have an adequate supply of MACK Brushes, but would like a display board, we'll send it to you - FREE.
2. The next time you place an order, just request one or more Display Boards to be sent with your order, at no charge. Remember, if the net amount of your invoice is over our minimum prepaid amount - we pay the freight.

SPEAKING OF BRUSHES . . .

There are two types of material to form the tuft of a brush:

SYNTHETICS are man-made of either nylon or polyester. They may come tipped, tapered, flagged, abraded or even etched to increase the brushes' ability to carry color. The man-made filaments may be dyed and baked to make them soft and more absorbent. The advantages of a synthetic brush are as follows:

1. They are very durable.
2. They are less likely to be damaged by moths, paints or mild solvents.
3. They are easier to clean.
4. If you are using an acrylic paint, use a synthetic brush.

NATURAL: No animals are raised or trapped for the sole purpose of making a brush. Natural animal hair may be used in its pure state or mixed with other types of hair to accomplish a particular mixture for price, and or, performance. Natural hair will hold a tremendous amount of paint, because it has microscopic scales along the shaft of the hair. Quality and price of natural hair is determined by the grade of animal, and by supply and demand. Generally speaking, longer hair is harder to find and more expensive than the shorter lengths.

TYPES OF HAIR:

SQUIRREL HAIR: Blue squirrel is the most readily available and comes in long lengths, as well as short lengths. It is generally used for striping brushes and lettering brushes. Brown, or kasan, is no longer as plentiful as it was several years ago. It is generally found in the shorter lengths and used for stripers, quills, and outliners. Both blue and kasan are very soft and fine. They point as well as kolinsky, but have very little snap, since the hair is not very resilient. Grey squirrel is the hardest to find and the most expensive. It is more durable, has more snap and makes a great quill or lettering brush.

CAMEL HAIR: There are no camel hair brushes. Camel hair brushes received their name from "Mr. Camel", who invented them. Camel hair could be squirrel, ox, pony, goat, or a blend.

PONY HAIR: It comes from an animal that is at least two years old. It is very strong, but also soft. The very finest pony hair comes from the belly of the animal. It is often blended with other hairs for less expensive watercolor and touch-up brushes.

OX HAIR: The best ox hair comes from the ears of cattle or oxen. It is very silky to the touch. It is also very strong, resilient and has good snap. However, it lacks a fine tip, so it is usually mixed with other natural hairs. The blending makes a brush more resilient and have more body.

RED SABLE: This hair comes from any member of the weasel family that has red hair. It does not come from the "sable" animal. It is used to make a lot of different brushes, and there is a big variance in quality when one speaks of "red sable". The good quality red sable can be used as a less expensive alternative to kolinsky. Quite often, red sable is blended with ox hair to make a more economical brush, but unfortunately, the fine point is sacrificed.

SABELINE: This is normally light color ox hair that is dyed to look like red sable. Some lettering and watercolor brushes are made with sabeline, mixed with sable, to lower the cost of the brush.

KOLINSKY SABLE: It comes from the tail of a mink. It is the best hair for watercolor and oil brushes because of its strength, spring and snap. It comes to a very fine point, and with proper care, will last many years.

BRISTLE: It comes from hogs in different parts of the world, but the very best comes from China. Hog bristle is different than any other natural fiber, since it forms a V-shaped split or "flag" at the tip, and has a natural curve. This gives it a resistance to fraying, and it spreads paint smoothly and evenly.

Camel Hair Striping Pencils*

SQUIRREL HAIR SWORD STRIPERS

SERIES 20

Actual Size #2



America's No. 1 Automotive Touch-Up Brush

Used by all leading Body Shops for Paint Touch-Up and Pinstriping

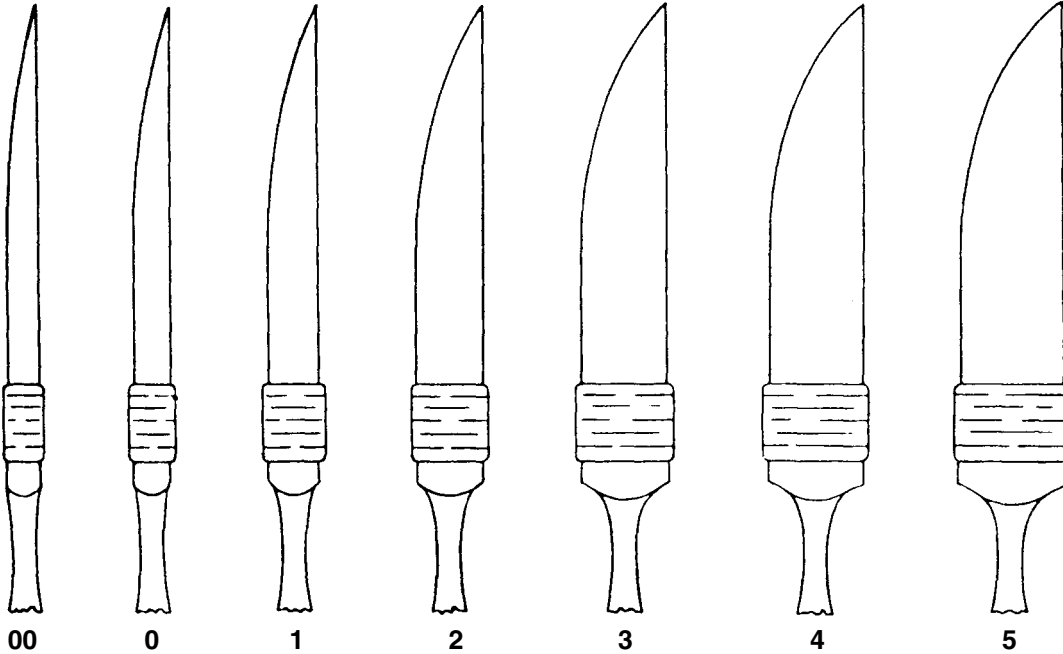

Sword Striper Assortment #2
Includes 2 Each of Sizes 00, 0 and 1

Squirrel Hair Mixture Stripers made Lacquer, Enamel and Water Resistant
The Sword Style is the Best for All-Around Work
Excellent for Auto Body Touch-up and Pinstriping

Sword Striper Assortment #5
Includes 1 Each of Sizes 00, 0, 1, 2, 3 and 4

All Brushes Made In U.S.A.

SIZES	WIDTHS							
	000	00	0	1	2	3	4	5
Sizes	000	00	0	1	2	3	4	5
Width of Head in Inches	7/32"	7/32"	1/4"	5/16"	13/32"	1/2"	9/16"	5/8"
Width of Head in MM	5.55mm	5.55mm	6.35mm	7.93mm	10.31mm	12.70mm	14.28mm	15.8mm

Regular Length of Hair: 2 inches - 5.08cm (Exception 000 1 3/4" - 4.445cm)

● CLEANING AND CARE ●

Always clean out a Striper thoroughly after use. The general rule for cleaning: the solvent or thinner that goes with the paint being used, becomes the cleaning agent. If the paint or medium you are using is compatible with mineral spirits or turpentine, we would suggest using this as the cleaning agent. When the Striper is cleaned, carefully wipe the hair without pulling, and fluff out until dry.

After cleaning, it should be placed in an acid free brush protector or preservative until next used. We recommend the Mack MBP-16 Brush Preservative. Hang it on a rack, hair down, for good protection.

Do not allow paint or cleaning agent into the glued part of the brush (the ferrule or area with the green or blue thread). Some paint and cleaning agents can attack the glue and cause the hair to loosen - especially a product that has a high percentage of methanol in it (over 5%).

● SOME CAUTIONS ●

Never soak the hair in water or let it lay in water. Never keep it in lacquer. Never use paint remover, paint softening preparations or lacquer retarder for cleaning purposes. Treat the Striper right and it will serve you well.

● CARDING ●

Stripers are mounted 6 to a card, all of one size.

However, we would be glad to package any size or combination on a 1/2 dozen card.

Examples:

Two each of any three sizes. One each of six sizes.

* (Camel hair brushes get their name from the Mr. Camel who invented them - they do not consist of camel's hair. Instead, the hair often comes from the tail of a squirrel.)

SQUIRREL HAIR DAGGER STRIPERS

SERIES 30

Squirrel Hair Mixture Stripers Made - Lacquer, Enamel and Water Resistant
All Brushes Made in U.S.A. - The Dagger Style is a Valuable Accessory for Many Purposes

New! Series 3010
"Made just like the series 30 but
using China Blue Squirrel Hair"
Sizes 000 - 4

Actual Overall Length — 4 1/2"

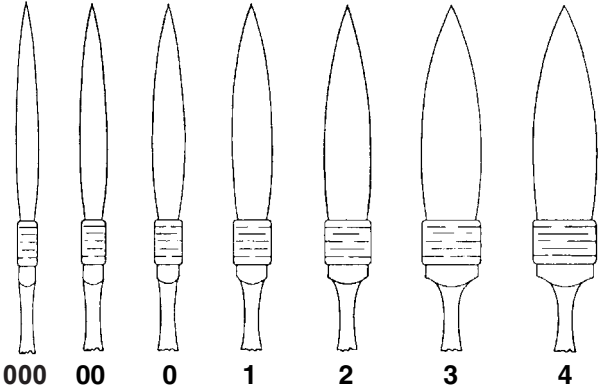
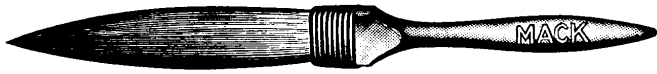

SIZES AND WIDTHS				
SIZES	000	00	0	1
Width Of Head In Inches	?	7/32"	1/4"	5/16"
Width Of Head In mm	?	5.55mm	6.35mm	7.93mm
SIZES	2	3	4	
Width Of Head In Inches	13/32"	1/2"	9/16"	
Width Of Head In mm	10.31mm	12.70mm	14.28mm	
Regular Length Of Hair: 2 inches - 5.08CM				

● CARDING ●

Stripers are mounted 6 to a card, all of one size.
However, we would be glad to package any size
or combination on a 1/2 dozen card.

Examples:

Two each of any three sizes. One each of six sizes.

Camel Hair Striping Pencils

SQUIRREL HAIR BROADLINERS -SQUIRREL HAIR MOULDING BRUSHES

SERIES 40 BROADLINERS

Squirrel Hair Mixture Made - Lacquer, Enamel and Water Resistant - Excellent Touch-up Brush
All Brushes Made in U.S.A. - Wideline graphics instead of a quill or stroke



Actual Overall Length — 4 1/2"

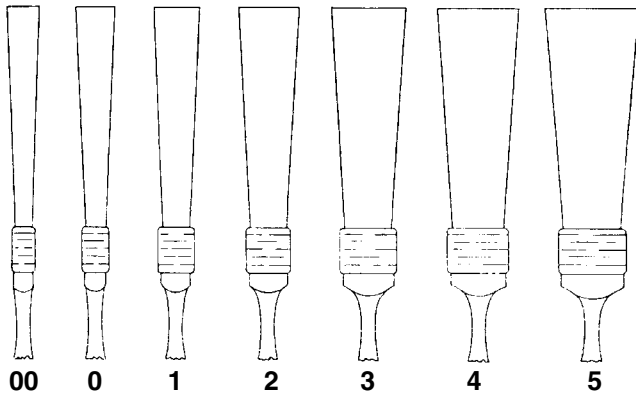

SIZES AND WIDTHS			
SIZES	00	0	1
Width Of Head In Inches	7/32"	1/4"	5/16"
Width Of Head In mm	5.55mm	6.35mm	7.93mm
SIZES	2	3	4
Width Of Head In Inches	13/32"	1/2"	9/16"
Width Of Head In mm	10.31mm	12.70mm	14.28mm
SIZES	5	6	7
Width Of Head In Inches	5/8"	3/4"	7/8"
Width Of Head In mm	15.8mm	19.05mm	22.22mm
Regular Length Of Hair: 2 inches - 5.08CM			

● BROADLINERS - MOULDING BRUSHES ●

These are adapted for broad lines, the size depending upon the width of line desired. Also good for blacking off mouldings, chair and table legs, refrigerator bottoms, and other sectional areas. Makes a great fill in brush on wide graphics (can replace a quill or stroke brush). Used on the edge, each size makes a slightly narrower line than when used flat. Universal for touch-up, for background work, and for varnishing limited areas.

SERIES 45 MOULDING BRUSHES

SQUIRREL HAIR MOULDING

European Dressed Squirrel Hair Mixture - Thread Wound, Lacquer, Enamel and Water Resistant

Regular Length of Hair 2 Inches (5.08CM)

1-1/2" (3.81CM) and 2-1/2" (6.35CM) - Hair Length Available Upon Request

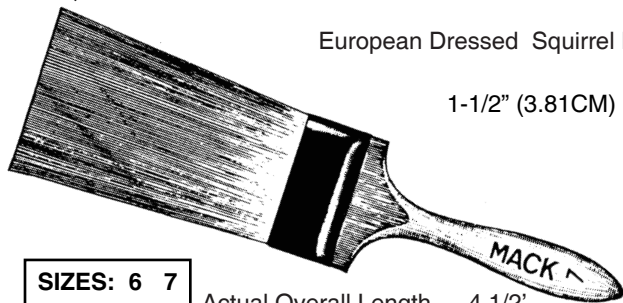

SIZES: 6 7

Actual Overall Length — 4 1/2"

● CARDING ●

Stripers are mounted 6 to a card, all of one size.
However, we would be glad to package any size or combination
on a 1/2 dozen card.

Examples:

Two each of any three sizes. One each of six sizes.

FOR PINSTRIPING, DESIGN & SCROLL WORK

Designed Just For Pinstripers

Original "Mack" Sword Striping Brush

FIEBING'S PRIME NEATSFOT OIL



MACK BRUSH PRESERVATIVE MBP-16 16 OZ.



Series #10

Actual Size #2
100% Unmixed Chinese Blue Squirrel Hair

Original Mack Pinstriping Brush Assortment #10 Includes 1 each of Sizes 000, 00, 0, 1, 2 and 3



Neatsfoot Oil NF0-16 16 oz. Bottle



- Hand crafted and shaped as it was many years ago.
- Extra attention given to Quality Control with respect to shape & cleaning.
- The very finest grade of Blue Squirrel
- Our new "Blue" thread ferrule.

SIZES	0000	000	00	0	1	2	3	4
Width of Head in Inches	3/16"	3/16"	7/32"	1/4"	5/16"	13/32"	1/2"	9/16"
Width of Head in MM	5.55mm	5.55mm	5.55mm	6.35mm	7.93mm	10.31mm	12.70mm	14.28mm
Regular Length of Hair: 2 inches - 5.08cm								

Hanson/Mack
"King 13"
Pinstriping Brushes



Andrew Mack & Son Brush Company has teamed up with Todd Hanson to create a brush called the "King 13" which is offered in sizes 00000, 000, 00, and 0.

We use a 60mm Chinese blue squirrel hair for the 00000 and 000 giving the brush a total length of 1 3/4". We use a 64mm hair for the 00 and 0 which gives the brush a total length of 2". The brush has more pull in the making process giving it a little more taper than a traditional striper. The amount of hair that is distributed onto the handle during the making process is configured differently than our series #10 or #20 brushes. For example, the 00000 and 000 are made on a #00 handle, the 00 is made on a #0 handle, and the 0 is made on a #1 handle. Our technicians are applying

the same amount of hair for a say a #00 brush but putting it on a handle that has a larger surface area. For the past several years, we have made these custom brushes for Todd with all the above attributes and decided it was time to put his name on the brush.

Series #13 Offered in sizes: 000000 / 00000 / 000 / 00 / 0 / 1

Three Innovative Stripers



The "Mack-Lite": The striper with less belly. The shape is similar to the "Old Dominican", which was discontinued years ago. Made with kazen squirrel hair and bound with a brass ferrule. Length out is graduated from 1-5/8" to 2". Available in sizes 00, 0, 1 & 2. **Series M-L**

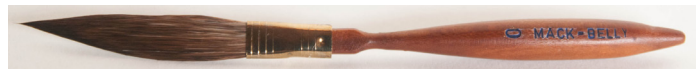

The "Mack-Belly": Exactly like the "Mack-Lite", only more "belly" to the shape in order to carry more paint. Same sizes & length out as the "Mack-Lite". Made with kazen squirrel hair. Available in sizes 00, 0, 1 & 2. **Series M-B**



The "Fast-Lite": Similar in shape to the "Mack-Lite" only the hair length is longer, and it is made with blue squirrel hair. Length out is graduated from 1-7/8" to 2-1/4". Available in sizes 00, 0, 1 & 2. **Series F-L**

Xcaliber Striper



Series X

Actual Size #00

Xcaliber Striper: What makes the Xcaliber special is its short blue squirrel hair length (only 1-1/2" vs. the average 2" & 2-1/4"). This shorter hair length allows greater control for intricate designs as well as long lines: Available in 0000, 000, 00 & 0.

THE MACH-ONE STRIPER SERIES #101



(#1 Actual Overall Length 5")



(#2/0 Actual Overall Length 5")

SIZES	00	0	1	2
Length Out	1-7/8"	1-15/16"	2"	2-1/16"

The Grumbacher Company was sold several years ago and the new company discontinued many of the quality brush products. When the two Grumbacher stripers were no longer offered we found the company who had been making these for Grumbacher and began offering the same brush, but with our name on the handle. Unfortunately that manufacturing company went out of business in mid 2002, so we worked with several "Grumbacher users" and developed our own version of the old Grumbacher 1010. We can not offer the 1020 black plastic handle, since we would have to buy too many handles to get a cost effective price. Stripers who worked with us to develop this new brush also suggested that it be a bit longer. From this research came the new "Mach-One"



Kelly-Mack



Actual Overall Length 4-1/2"

Tom Kelly's grandfather, O.Z. Crozier, (aka) "The Baron" of Baron Roth & Kelly started striping wagons & buggies for the Studebaker Bros. in the early 1900's. He then striped at the Ford Motor Co. for over 25 years through the 20's-30's and part of the 40's. In the early 50's when striping returned to cars in a custom style, I asked the Baron to stripe my friend's car and he did. My grandfather thought it might be good to go into business striping and he asked me, Kelly, to work with him, so I did. I've been striping every day for the last 50-plus years. The only brush the Baron and I have ever used is a #1 & #2 Mack Sword Striper from the Andrew Mack Brush Co. For all the new stripers coming into the business, don't be afraid to use a larger brush, you can do anything the smaller brush can do, but the larger brush will go further on a single load of paint.

SERIES	SIZES
K/M	1
K/M	2
K/M - SET	

Wipe Out Tool Series 2240



Actual Overall Length 7-1/2"

& Series 2205



If you over run a corner or edge, this wipe out tool can pull or push the paint away to make a perfect edge or corner.
 2240 - Black Handle - Gold colored ferrule - Hard Blue Rubber Tips
 2205 - Has a tapered point and the other end is angled chiseled - Hard Pink Rubber Tips

Mack SLS

Actual Overall Length 4-3/4"



SERIES	SIZES
SLS	00
SLS	0
SLS	1

This striper has a mixture of black synthetic and blue squirrel hair. We have had recent success with this blend of hair and decided to put it in a striper. This chrome ferruled brush has a length out of 1-7/8". This brush will perform well in all mediums of paint with the emphasis being used with urethanes.

Mack-Norris Trickster



Actual Overall Length 7"

SERIES	SIZES
M/NT	00
M/NT	0
M/NT	1

The Trickster is a striper with a handle length of 4-1/4". Jim Norris helped design this brush and with his sign painting background likes the longer length of a brush handle. For the stripers that prefer a shorter handle the modification is quick and easy. The striper is made of pure blue squirrel hair and has a length out of 2-1/4". The long length of the hair allows the brush to carry a good load of paint for a long distance.

You can stand the brush up on the tip to create super fine lines even with the larger sizes.

"I just worked with your Norris trickster. In 34 years, probably the nicest long line brush I've ever used."

(Testimonial letter sent to Mack Brush — 12-15-06)

—Sincerely, Bob Iverson

SERIES	SIZES
1010	00
1010	0
1010	1

Mack 1010



Actual Overall Length 5"

Back by popular demand for all the Grumbacher 1010 fans.

Brown Wood Handle

Peewee 800

LongLiner

Don't let the name of this brush fool you!

This is a very capable and useful brush made for long lines and a superb brush for design work, and an excellent choice for outlining flames, graphics, etc.

After 17 years of using Cosmos then DaVinci 700 long liners for all of my line work I noticed the dreaded "hair falling out syndrome" then the shape consistently changing as the selling price of these brushes continued to rise. All the while always having to grab my trusty Mack blue wrap (series 10) for my design work or any time I had flames or graphics with lots of turns. I'd finally had enough. So teaming up with Mack Brush Company to develop a brush that combined the best of both worlds the Peewee 800 LongLiner was born!

This wasn't a one time "hey make a brush like this guys" type of thing. It took many tries and quite a few design changes to ensure the "butterknife" or "sword" shape was just right, not to mention the hair count was refined to maximize the paint carrying abilities for those long lines this brush was intended for.

In a nutshell, this is a highly refined Mack Series 10 built with a purpose, and with being a Mack rest assured it will be a workhorse that won't let you down!



Series #800 Offered in sizes: 00 / 0 / 1

Gonzalo (Peewee) Curiel - Since 1977

Presenting The - DC FLATLINER - Series 1310

Actl.



This new brush is a "work horse" - it's designed for long lines. The squirrel hair comes from China and it is softer than the traditional Siberian squirrel hair. It's the same hair we use in our #10 Original Mack Striping Brush. It's a very "fast" brush and lays out long lines.

SIZES	00	0	1
Length Out	1-5/8"	1-3/4"	1-7/8"

The Long Handle Striper

30% Smaller Than Actual Size



Series #250 Black lacquered handles Series #251 Plain handles
Available in sizes 000, 00, 0 & 1 Graduated hair length from 1-5/8 to 2"
Brown kasan squirrel hair - Seamless nickel ferrules - Overall length 8-1/2" to 9"

PINSTRIPING BRUSH - For Waterbase & Acrylic Paint



Actual size

Series #70 - Mixture of Squirrel Hair & Taklon

Made very similar to our Fast-Lite Striping Brush - but with mixed hair to give the brush more body. Water base paint has a higher density and we must mix taklon with pure squirrel for body & snap, but we must keep a generous amount of pure squirrel in the brush to carry enough paint to make it a good striper. A great outdoor striper on a windy day - holds its body & shape.

SIZES	00	0	1	2
Length Out	1-3/4"	1-13/16"	1-7/8"	2"

THE ULTIMATE LONG LINE STRIPER

Glawson/Mack Extra Long Striper

Series 1644



Actual Overall Length 5-1/2"

This brush is shaped like a Fast-Lite Striper.

Available in sizes #0 & #00, & #1.

Both sizes have a hair length out of 2 1/4". Wood handle, brass ferrule, Pure Blue Squirrel Hair. This striper can be used with either lettering enamel or urethane paint.

Rick said, "They are great for long thin lines!"

Series 1645



Actual Overall Length 5-1/2"

This brush is shaped like a Fast-Lite Striper, but with a hair mixture of Squirrel and Brown Taklon for more body and snap. Available in #00 with a hair length of 2 1/4".

Also good for water base paint or any other paint that is more dense than lettering enamel.

TAKLON STRIPER

Series 75



Actual Overall Length 4-1/2"

SIZES	00	0	1
Length Out-Trim	1-3/4"	1-3/4"	1-3/4"

This is a synthetic striper with a wood lacquered handle and brass ferrule.



Series JS MACK SIGNATURE BRUSHES

"The Jenson's Swirly Q brush is designed for scroll striping and script lettering with enamel based paints. Scroll striping requires thinner paint, if mineral spirits were to be used the paint would run easier. I recommend using a slow drying automotive reducer for thinning enamel based paints, these can be purchased at your local autobody supply. Clean brush thoroughly with reducer before and after each use (do not use lacquer thinner!). Be sure to store your brush in mineral oil between uses."

— Gary Jenson

75% of actual size



Made in 2 Sizes

JS-1 Hair Length out - 1-7/16"

JS-2 Hair Length out - 1-11/16"

Series AJ ALAN JOHNSON SIGNATURE BRUSH

80% of actual size

"The Original AJ #2/0 Signature Brush"



This is the very special brush that your fellow pinstriper Alan Johnson uses to sign his panels. Made with a special taklon and is excellent for detail work.

AJ "The Extreme Liner" Series AJ/EL

Actual Overall Length 7-1/2"

AJ/EL-0 "THE EXTREME LINER" MACK USA

SERIES AJ/EL

SIZES	0	1	2
Length Out	1"	1-1/4"	1-3/8"

"The Extreme Liner" is made with blue squirrel hair which holds a good load of paint to carry a very fine line a very long way. Alan Johnson designed this brush especially for outlining gold lettering where crisp fine lines are essential. It works fantastic for tight intricate work.

AJ Mini Detailer Series AJ/MD

Actual Overall Length 7-1/2"

AJ/MD-1 "THE MINI DETAILER" MACK USA

SERIES AJ/MD

SIZES	1	2
Length Out	14/16"	1"

"The Mini Detailer" is made of dark brown synthetic hair with a nice chiseled edge. Alan Johnson designed this brush for painting small lettering, elaborate emblems, ornaments, cartoons, etc...

THE HANNUKAINE QUILL

- NICE EDGE
- LOTS A' SNAP
- LONGER LIFE
- OIL & WATER MEDIA
- PRICED RIGHT
- 100% FAT FREE

AVAILABLE IN 6 SIZES

Series #79 - Mixture of Brown Synthetic Squirrel

- XXS Similar To A Size #2 Graduated Quill
- XS Similar To A Size #3 Graduated Quill
- S Similar To A Size #4 Graduated Quill
- M Similar To A Size #6 Graduated Quill
- L Similar To A Size #8 Graduated Quill
- XL Similar To A Size #10 Graduated Quill

Sold individually or save by buying a 6 pc. set

75% of actual size

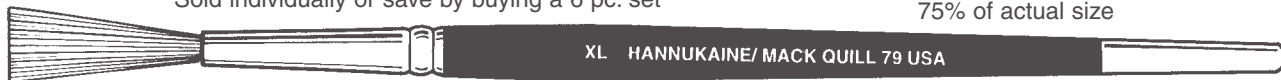

EXTENDED QUILLS

The hair length on all these quills is longer than our traditional quills.

SERIES Q/M-B (brown)

90% of actual size



The Quinn/Mack Brown Quills Have A Natural Lacquer Handle (Paul Quinn)

SIZES	0	1	2	3	4	5	6	8	10	12
Length Out	1"	1-1/4"	1-1/4"	1-1/4"	1-1/4"	1-1/4"	1-1/2"	1-1/2"	1-1/2"	1-3/4"

SERIES Q/M-G (grey)

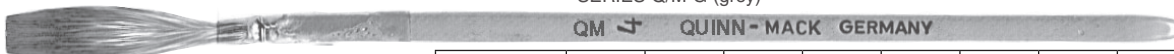

The Quinn/Mack Grey Quills Have A Pink Handle (Paul Quinn)

SIZES	1	2	3	4	5	6	8	10
Length Out	1-1/4"	1-1/4"	1-1/4"	1-1/4"	1-1/4"	1-1/2"	1-1/2"	1-1/2"

SERIES 444 SCROLLING/SCRIPT "THE VIRUS"



SIZE	0	1	2	4	6
Length Out	7/8"	1"	1-3/16"	1-5/16"	1-3/8"

The series #444 scrolling script is a specially blended golden taklon. This recommended design by the industry leaders is perfect for scroll and script work.

Series #444 Virus II



Actual Overall Length 8"

SIZE	0	1	2	4
Length Out	7/8"	1"	1-3/16"	1-5/16"

The Virus II is made of a soft golden synthetic hair. Designed by "Dave the Letterman" to appease the small crowd of painters who thought the original virus was a touch to stiff. So we decided to make the brush with the same specifications as the original but with a golden synthetic hair that is a little softer. This brush will still be used for the same applications of scroll and script work.

Myers-Mack Phat Handled Brush Series M/M

Actual Overall Length 7-1/4"

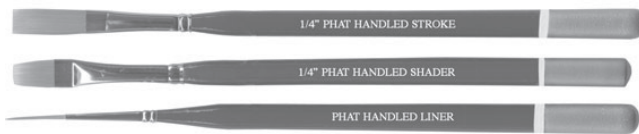

M/M 1/4" Shader • M/M 1/4" Stroke • M/M Liner

The handle of the brush was the starting point of this brush design. The handle is a little larger in circumference than a pencil with a dramatic taper into ferrule of the brush. Ron Myers helped design this brush because he liked the feel of this larger handle. He calls the three brushes

that make up this set "The Car Show Set". Ron goes to several car shows a year and likes the fact that he only has to rely on these three brushes and a #10 striper. The 1/4" stroke and liner are straight forward brushes used in traditional fashion. The 1/4" shader was designed for wet on wet paint blending. These extremely durable brushes are made of taklon and are all sold individually.

MIKE LAVALLEE'S PICTORIAL BRUSH SET Series L/M

50% of actual size

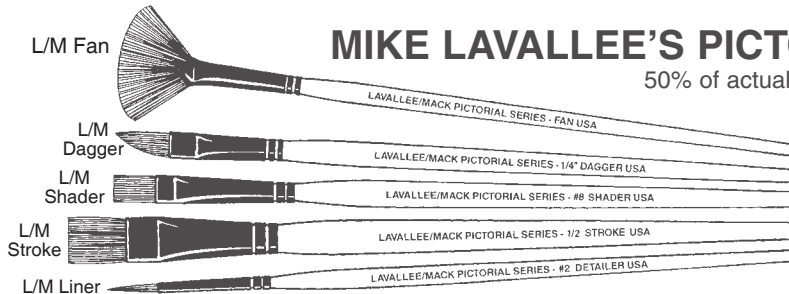

Hi, my name is Mike Lavallee. I have been in the sign and custom paint business for 20 years making the better part of my living with my pictorial art, and pinstripping for customers from all over the world.

*Working with the Andrew Mack and Son Brush Company, we have developed a new line of quality pictorial brushes called **BLACK GOLD**.*

BLACK GOLD - The finest quality multi-diameter, silky soft, flagged Taklon, specially selected and blended together to achieve the performance of the best red sable with the durability of a synthetic brush. The ratio of our blend gives you a unique and superior capillary action in the release of color, far beyond other single diameter material offered by other manufacturers.

These brushes are very versatile and durable, and I recommend you try them for all your pictorial needs. Also, you can use the two flat brushes for some incredible dry brush effects.

*For years I tried to paint pictorials with conventional sign brushes, but just didn't get the effect I wanted, not to mention the abuse I put my brushes through! The **BLACK GOLD LAVALLEE/MACK SERIES** are the answer to that problem!*

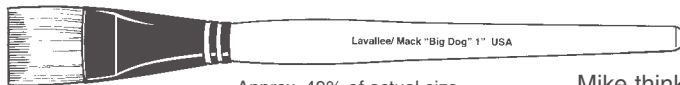

Approx. 40% of actual size

Series L/M BIG DOG

Mike thinks that some people who do larger pictorials will enjoy this brush.

STABILO and OMNICHROME PENCILS!



75% of actual size

Available in White #8052

Dark Blue #8041

Red #8040

Black #8046

Graphite #8008

Yellow #8044

The Stabilo Pencil is great for making guide/lines on a sign surface. You can paint over the lines or remove them with a damp cloth. Paint will not flake or peel off when the guide/marks are painted over. **OMNICHROME PENCILS** (Series 108) offered in white, black or blue.

BRUSHES FOR GOLD LEAF



Gilders Tip Series 1138

One popular size: 3 1/2" x 2 1/4" length out. Single thick Blue Squirrel Hair.

The single thick tips are more popular than the double thick, since you can see through the single thick hair and you are less likely to make an error.

RON PERCELL'S TRIPLE TIP

A Gold Leaf Application Brush for Loose Leaf on Glass, Metal & Wood.

This universal gilder's tip capable of holding "Full or Small" sheet or pieces of loose Gold, Silver and Palladium precious real leaf. Excellent for transferring Gold Leaf when surface gilding on oil based gold sized, cars and trucks, carved dimensional lettering and gilded picture frames.

Great for water gilding with gelatin on large and small reverse glass lettering and mirroring. Suitable for alcohol, oil, and water based gilding with real Gold or Silver Leaf. **Series RP-7**



Japan Brush Series 1646

The hair length in all three sizes is approximately the same - 1 1/4" out. The Japan Brush is made with Black Goat Hair and a plain lacquered handle. Japans are great for painting backgrounds, especially glass backgrounds. They are great for pushing paint out of the way without leaving lines or streaks. The Japan Brush is also used for sizing large letters and objects. After you have gilded you can use the Japan Brush to brush off the 'tails'. It will brush off without damaging the Gold Leaf. You can brush vertical, horizontal or diagonal and the gold will show the direction of the brushing, without damaging the surface.

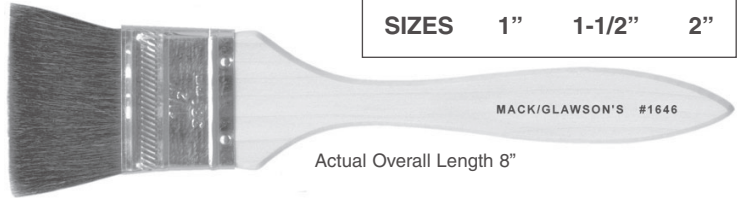

SIZES	1"	1-1/2"	2"
-------	----	--------	----

Actual Overall Length 8"

Stencil Brush - Series 113

Actual Overall Length 8-1/2"



A Stencil Brush can be used for sizing in carved and depth blasted glass, because the bristles are rather stiff. They can also be used for wall ornamentation, stencils & faux finishes. Great spatter brush.

SIZE	#2	#4	#8	#12
Diameter	1/4"	3/8"	1/2"	5/8"

These are many other types of Brushes used in Gilding & Gold Leaf that are already in our product line (Catalog #08)

- QUILLS - Brown (series 179 & 179L), Grey (series 189 & 189L), catalog page 17
- SOFT FITCH - Series 4031 & 4039 - page 23
- LINERS - Series 839 - page 19, JS-1 & JS-2 - page 6
- STRIPERS - Many to choose from - pages 3, 4 & 5

Gilders Sizing Brush Series RP-5 - (Formally RP-2)

This brush was designed for water gilding glass with loose leaf in reverse for Signage, Art, Decoration and much more. The hair is squirrel hair and wrapped with a stainless steel ferrule and attached to the handle with stainless steel nails. The handle is made from wood and painted black. The handle also has a hanging hole. The overall length is 6-1/2". The width of the brush is 1-1/2" and the hair length out is 1-1/4".



Actual Overall Length 6-1/2"

Available in one size only

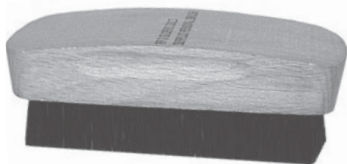

Actual Overall Length 5"

Gilders Gold Surplus Removal Brush Series RP-3

Available in one size only

Gilders Gold Surplus Removal Brush for "Water Gilding". This brush was inspired by a great little "OLD" brush used by a sign writer and gold leaf master out of Australia - the Late John Jordan. John still had the original and used it on a regular basis. This brush is used for the removal of precious metal leaf when water gilding glass in reverse for Signage, Art, Decoration and much more. The handle is made from wood. The trim out is 3/4", and the wooden block is 2-1/8" x 4-3/4". The block has rounded ends and top with hand grooves in the sides. Use this brush after your back-up paint has completely dried. You may use a damp cloth (not dripping wet) and slightly moisten the surface, then brush gently over any surplus leaf in a pendulum action to remove surplus material.

RP-4 Gilders Tip for "Loose Gold"

This brush was designed for beginners wanting to try water gilding glass with Loose Leaf in reverse for Signage, Art, Decoration and much more. Great to use with precious metals such as Gold, Silver, & Palladium Loose Leaf.

Actual Overall Length 4-3/8"

Available in one size only



MACK BRUSH ITEMS

“Scroll Stripers” by the Wizard! **Series WV** “Wizard Vortex” Blue Squirrel - Grey Handle



Shown Actual Size

Available in 3 Sizes: Series WV-0, WV-1 and WV-2

Wizard Vortex - “If you use scroll striping, you’ll love this brush! After 30 years of scrolling we’ve developed what I think is the finest brush available for this style. It gives beautiful controlled lines that respond exactly to your movements without the slightest hesitation, splitting or fraying in the turns. It holds its line throughout the pattern and gives you more response - like the most expensive brushes used for scrolling. I recommend this for beginners as well as seasoned veterans of this style.”

—Steve Chaszeyka

Series WV “Wizard Typhoon” Kazan Squirrel - Bronze Handle



Shown Actual Size

Available in 3 Sizes: Series WT-0, WT-1 and WT-2

Wizard Typhoon - “Just a ‘hair’ faster than the Vortex, but with all the quality, this baby moves right along. As fast as you can think of a design, the typhoon seems to read your mind and anticipate your next move. The hair was chosen for quick response time and accurate placement on any surface. I especially like this brush for motorcycle work because of the curved surfaces and the brushes ‘forgiveness’ in tight turns. I am amazed at its performance every time I use it.”

—Steve Chaszeyka

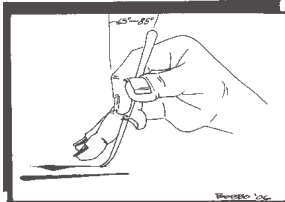

SERIES B/M SQ

SIZES 00 0 1 2

Actual Overall Length 4-1/2”

Bobbo-Mack Super Quad Series BM/SQ



BOBBO’S NEW “SUPER QUAD” 4 ACTION BRUSH

This is another development between Bobbo and Mack Brush Co. to bring to the pinstriper-artist a new brush to fulfill some of the difficult tasks of using a brush to it’s fullest. This brush because of it’s shorter bristles and fine blue squirrel & black synthetic hair makes scrolling easier and faster. It also pinstripes short lines, 2-4 feet in length without having to change brushes. Plus it will let you letter your signature very small and also do small script lettering. This brush has adequate snap and flexibility other brushes don’t have. This allows the pinstriper/scroller to use one brush for four purposes without having to change brushes or color. The drawing to the left shows the correct position to hold the brush, 65-85 degrees and only using one fourth inch to only one half inch of the tip. Any deeper into the hairs will widen the lines and disfigure your artwork. Heavy pressure and lifting the brush as you drag your line will give a long teardrop effect. The drawing shows how to use the brush.

LONG BOB PINSTRIPING and SCROLLING BRUSH

Series LB

This brush offering, is a modification of the Bobbo Super Quad. We are using the same mixture of hair that is offered in the Bobbo, which is a black synthetic and blue squirrel blend, but with extended hair lengths of 1 ¾” to 2”. We have had great success with the Bobbo brush, and have had requests for a longer hair length version. We offer this brush in four different sizes which are 000, 00, 1, and 2. With the mixture of hair that is used, this provides medium versatility for enamels as well as urethanes without compromising performance. The smaller sizes offer intricate design work capabilities coupled with very tight cornering. As you progress to the higher sizes the brush will allow you to do longer line work with thicker consistent line quality. These brushes will offer the individual a high quality striper, outliner, and scroller.

Series 7800

This brush has all the same attributes and capabilities of the Bobbo Super Quad but in a long handled version.

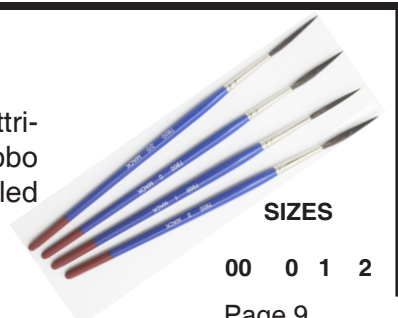

SIZES

00 0 1 2



SIZES 000 00 1 2

15-PIECE SPRAY GUN CLEANING KIT - The Complete Package

Series 1200-K

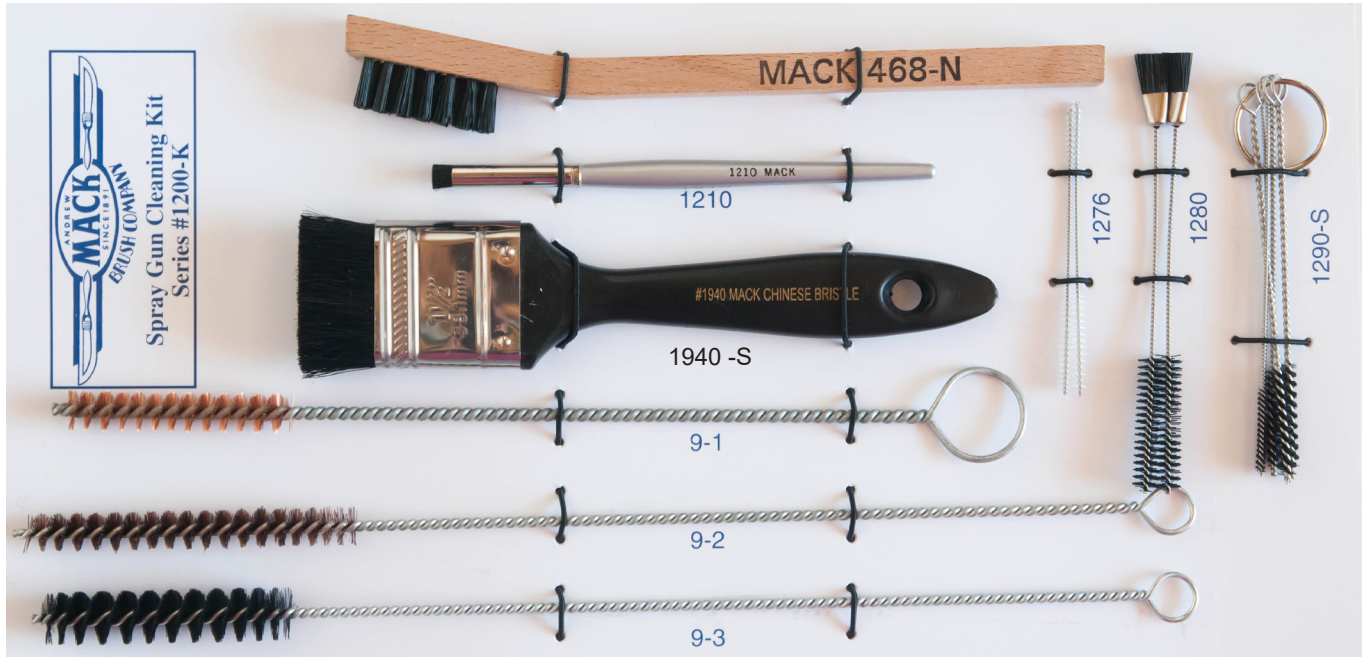

All brushes on this card are also available in open stock.
A COMPLETE LISTING OF ALL BRUSHES IS FOUND BELOW:

SPRAY GUN CLEANING BRUSHES //

Ideal For Cleaning Spray Guns, Hoses, Striping Tools, Air Brushes, Touch-Up Guns

	Series #	Filament	Std. Pack	Use
9-1	9-1	Stiff Horse Hair	6 Brushes Per Bag	These brushes are a necessity for all types of external and internal cleaning jobs. They can be used with all types of cleaning solvents. The three different sizes cover most applications. Packaged in a plastic bag with zip lock and hole for display hanging.
9-2	9-2		6 Brushes Per Bag	
9-3	9-3		6 Brushes Per Bag	
9-Set (Set of 3)	9-Set	3 Brushes Per Bag		

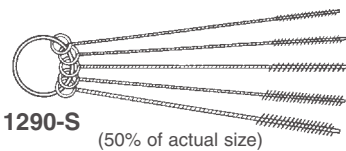

Series 1290-S: Five different size brushes on a wire ring. One set per plastic bag with header card. Specialized black bristle brushes for cleaning spray guns, air caps, air passages & fluid nozzles.

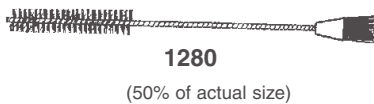

Series 1280: Specialized black bristle brush for cleaning spray guns. Packed 6 per plastic bag with header card.

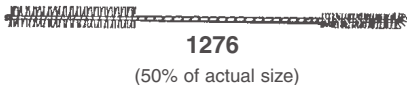

Series 1276: Specialized white bristle (bristle on both ends) brush for cleaning spray guns, air caps, air passages & fluid nozzles.



Series 1210: Exacto type handle with removable (replaceable) brush head. Black bristle brush length out = 1/4". Overall length of brush head & handle = 6".
1210-H = Handle 1210-B Brush Head

Series 468-N Mini Scratch: Found on Page 12 - first item ★

Series 1940 Detail Brush: Found on Page 12 - third item ★



Economy
Spray Gun
Cleaning Kit
600-K



#SGCK-1 Spray Gun Cleaning Kit

Includes:

- 1 - #1232 - 32 oz. polyethelene wash bottle with small spray cleaning tube/nozzle
- 1 - #1290-S 5 brushes on a ring
- 1 - #9-3S 8" horse hair brush
- 1 - #1940-S black chinese bristle
- 1 - #1225 double ended metal dental pick
- 1 - #1210 6" brush with metal utility handle
- 1 - #1230 blue metal box with 13 tip cleaners
- 1 - #468-N nylon mini scratch wooden handle



#1290-S (40%) of actual size



#1232 (40%) of actual size



#9-3S (40%) of actual size



#1940 (40%) of actual size



#1225 (40%) of actual size



#1210 (40%) of actual size



#1230 (50%) of actual size

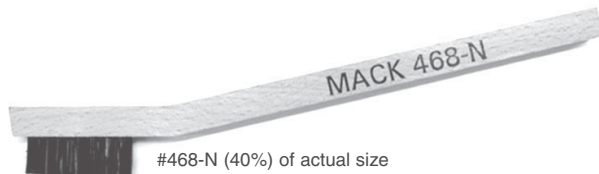

#468-N (40%) of actual size

#ACK-1 Airbrush Cleaning Kit

Includes:

- 1 - #1216 - 16 oz. polyethelene wash bottle with small spray cleaning tube/nozzle
- 1 - #1290-S 5 brushes on a ring
- 2 - #1276 3" white bristle double ended brushes
- 2 - #1280 4/12" black bristle double ended brushes
- 1 - #2701 6" black nylon brush with loop on one end
- 1 - #1210 6" brush with metal utility handle
- 1 - #1230 blue metal box with 13 tip cleaners
- 1 - #1225 double ended metal dental pick



#1290-S (40%) of actual size



#1216 (40%) of actual size



#1276 (100%) of actual size



#1280 (60%) of actual size



#2701 (50%) of actual size



#1210 (40%) of actual size



#1230 (40%) of actual size



#1225 (40%) of actual size

500ML Wash Bottle

This is a wash bottle that offers flexible walls for easy squeezing and a wide mouth for easy filling capabilities. The bottle and tabulation is molded in one piece of LDPE with a polypropylene screw closure. The dispensing tube gives the user an ultra-fine stream of liquid. Remember, to slightly loosen the cap to prevent liquid from dispensing when not being applied. **Series 500ML**



DETAIL - MINI SCRATCH - WELDER //

Great For Parts Cleaning, Detail Work,
And To Reach Small Tight Areas



Series #	Filament	# Rows	Length	Trim	Std. Pack
468-SS	Stainless Steel	3x7	7-3/4"	1/2"	36
468-B	Brass	3x7	7-3/4"	1/2"	36
★468-N	Nylon	3x7	7-3/4"	1/2"	36
468-HH	Horse Hair	3x7	7-3/4"	1/2"	36

Use

468-SS: Cleaning engine parts - cleaning threads before and after welds. Resistant to corrosion and high temperature.
468-B: Parts cleaning - non sparking - static free.
468-N: All purpose - can be used with solvents and cleaners. Chemical resistant for durability.
468-HH: Softer than nylon - good detail brush, removes polish, wax, etc., from body-chrome and rubber.



Series #	Filament	# Rows	Length	Trim	Std. Pack
468	Stainless Steel	3x7	7-3/4"	1/2"	36
SS/BR	Steel & Brass	Both Sides			

Two Sided Brush - "One Brush Will Do The Job Of Two"

468	Horse Hair	3x7	7-3/4"	1/2"	36
HH/WN	& White Nylon	Both Sides			

Use

Same as above uses for stainless steel & brass.

Same as above uses for horse hair & nylon.

DETAIL BRUSH // All Purpose



Series #	Filament	Size	Trim	Std. Pack
★1940	Black Chinese Bristle	1-1/2"	3/4"	12

Use

Used to remove polish and dirt from around chrome strips and seams. Can also be used as a mini whisk broom or upholstery brush in hard to get to areas. Hole in handle for hanging.

WIRE SCRATCH - SHOE HANDLE // General And Heavy Duty Cleaning



Series #	Filament	# Rows	Length	Trim	Std. Pack
1190	(Domestic) Oil Tempered Steel	4x16	10"	1-1/8"	12
1190-SS	(Domestic) Stainless Steel	4x16	10"	1"	12

Use

Designed for cleaning all rough surfaces on a variety of materials to remove paint, dirt, rust and stubborn deposits. Shoe handle features a contoured grip for strong and constant use. Hole in handle for hanging.

Same as above, but less expensive.

Made with stainless steel rather than oil tempered steel.

WIRE SCRATCH - CURVED HANDLE // General And Heavy Duty Cleaning



Series #	Filament	# Rows	Length	Trim	Std. Pack
1193	(Domestic) Oil Tempered Steel	3x19	14"	1-1/8"	12
1193-SS	(Domestic) Stainless Steel	3x19	14"	1-1/8"	12

Use

Designed for cleaning all rough surfaces on a variety of materials to remove paint, dirt, rust and stubborn deposits. Curved handle for easy reach. Hole in handle for hanging.

Same as above, but less expensive.

Made with stainless steel rather than oil tempered steel.

WIRE WHEEL SPOKE BRUSH // All Purpose Cleaning Fancy Wheels - Wire & Spoke



Series #	Filament	Dimensions	Trim	Std. Pack
7030-T	Tamphir Fiber	14-1/2" Overall Length	2-3/4" Diameter Which Tapers to 1-1/4"	12

Use

The ideal brush for removing built-up dirt between spokes. The bristles are stiff Tamphir twisted in wire. The handle is made of natural hardwood (5"). Wire ring at end of handle for hanging.

VEHICLE WASH BRUSH // All Purpose Wash Brush

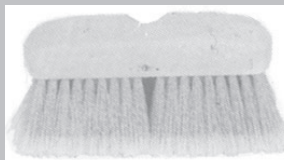

Series #	Filament	Dimensions	Trim	Std. Pack
7089	White Synthetic Fiber	9-1/2" Molded Block With Bumper	2-5/8"	1

Use

This fountain style brush cleans trucks, buses, trailers, RV's, campers, large window areas, fences, aluminum siding, etc. It can be used on indoor or outdoor surfaces, like wood floors, concrete patios and asphalt. Molded block has threaded hole for fountain handle and a plain hole for use with a tapered handle. Head only (no handle).

UPHOLSTERY BRUSH // All Purpose Cleaning



Series #	Filament	Dimensions	Trim	Std. Pack
7070	Poly Fill	6" Poly Molded Block	1-1/8"	12

Use

Perfectly sized for quick and easy clean-up of car and other vehicle interiors. Shaped to fit the hand and made of long lasting - no skid - polypropylene. Ideal too for cleaning vinyl tops.

NEW PRODUCT - DASH & VENT COMBO BRUSH



Series #
15313
Overall Length 12"

TWO USEFUL BRUSHES IN ONE
 Bristle cleans nooks & crannies
 Duster helps remove dust from dash
 One Brush per Hanging Card • 12 Cards per Master Pack

AUTO DASH BRUSH // Interior Cleanup Brush

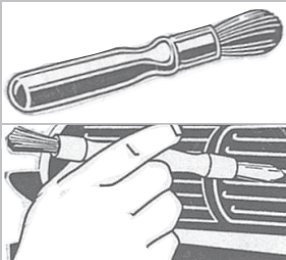

Series #	Length	Trim	Std. Pack
640	6" Overall	1-5/8" Out	One Per Blister Card 24 Per Master Carton

Use

This wonderful little brush whisks away dust & dirt in all those places towels & rags can't reach. Specially treated bristles "pick" dust & dirt in a single stroke. Good for air vents, car phones, gauges & recessed areas. Best for fine plastic & wood finishes.

The 2 in 1 dash brush. Superior quality brush . . . extracts dirt and dust easily. Even in recessed cracks and crevices. Keeps interior looking clean and fresh. Small size for easy storage. Soft, gentle bristles . . . best for fine plastic and wood finishes. Stiff bristles for hard to clean areas. Just like professional detailers use.

SUPERIOR PARTS CLEANING // Heavy Duty - All Purpose - Parts Cleaning



Series #	Filament	Lgth. & Ferr.	Trim	Std. Pack
127-N	Crimped Nylon	11-3/4" Aluminum Ferrule	2-3/4"	12
127-NI	Crimped Nylon	10-3/4" Aluminum Ferrule	2-1/4"	12

Use

This brush is superior to all other filaments be-cause of its long life. The relatively blunt end adds to the life as well as more overall surface action. The nylon bristles are resistant to swelling and softening when used with acetones, oil, thinners, solvents and most acids. Bristles are bend resistant. Hole in handle for hanging.

Same uses as above, less expensive, imported from Taiwan.

PARTS CLEANING // Heavy Duty - All Purpose - Parts Cleaning



Series #	Filament	Lgth. & Ferr.	Trim	Std. Pack
128-P	Crimped Polypropylene	11-1/2" Aluminum Ferrule	2-7/8"	12

Use

Will not last as long as nylon, but poly is less expensive. Our poly brush features a dome or pointed bristle shape. Also resistant to most acids, acetones, gas and ketone's. Poly has a low specific gravity. Hole in handle for hanging.

PARTS CLEANING // Light Duty And Fine Parts Cleaning



Series #	Filament	Lgth. & Ferr.	Trim	Std. Pack
129-H	Pure Black Hog Bristle	10-3/4" Aluminum Ferrule	2-1/4"	12
129-HW	Pure Black Hog Bristle	11-1/4" Aluminum Ferrule	2-5/8"	12
130-T	Red Mix Tampico	11-1/2" Aluminum Ferrule	2-7/8"	12

Use

Hog bristle is great for fine cleaning - non scratching. It is not resistant to acids & alkalines. Good cleaning brush for spray guns, air caps, fluid tops, & misc. parts.

Same as above but some thinners will attack the poly handle, so we are now offering this brush with a wooden handle. Both brushes have hole for hanging.

Tampico is a light duty parts cleaning brush excellent for transferring liquids from container to applications because it absorbs so well. Tampico is water and alkaline resistant. Hole for hanging.

ACID BRUSHES // General Purpose Flat Face, Tin Handle

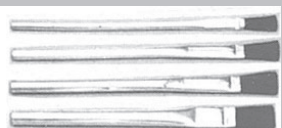

Tin Handles

Series #	Size	Filament	Width	Length	Std. Pack
7	0	100% Stiff	1/4"	6"	12 dz.
7	1	Horse Hair	3/8"	6"	12 dz.
7	2		1/2"	6"	12 dz.
7	3		9/16"	6"	12 dz.

Use

Great for motor and engine cleaning and repair. Excellent for applying acid, paste, glue and solder in difficult to reach areas. Excellent for lead work, spreading solder & seam sealing.

POLY BRUSHES & ROLLERS

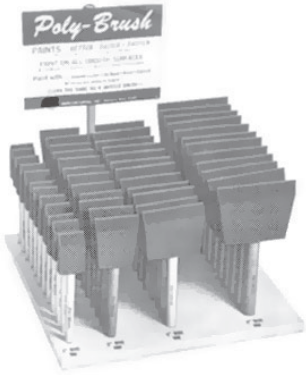

PB-1 DISPLAY ASSORTMENT

Poly Brushes are packed as follows:
Display assortments of 12 each size
1", 2", 3", 4", with base and sign.

HANDLES

- 3" Roller Handle • 9" Roller Handle
- 3" Throw-Away Roller Handle
- 9" Throw-Away Roller Handle

Our poly brush is the profitable throw away brush which is so easy to use that even inexperienced painters go for it. Then they come right back to you for more Poly Brushes and, of course, more paint. You gain two ways.

Poly Brush is for all smooth surfaces, ideal for the application of enamel, latex, stains, oil paints and varnish, but not for shellac or lacquer. Poly Brush smooths out the paint and covers correctly with fewer strokes. Leaves no brush marks or loose bristles. The brush stands number one among foam brush manufacturers.

Rollers and Brushes

Series #1014



OPEN STOCK

- Boxes of 48 each 1" poly brushes • Boxes of 48 each 2" poly brushes
- Boxes of 36 each 3" poly brushes • Boxes of 24 each 4" poly brushes
- Boxes of 24 each 3" poly rollers • Boxes of 24 each 9" poly rollers

DETAIL PREP TOOL SERIES #150

The Detail Prep Tool is a fiber burnishing brush used for removing rust and preparing a surface for a long lasting paint application. The glass fibers are very fine, but they are stronger than steel.

- Cleans away wax, road film & rust.
- Electrical- Cleans & prepares an area for soldering. Cleans electrical connections, contacts, cable ends and tools.
- Cleans & prepares areas for painting.
- Cleans & prepares any metal surface for painting, gluing & any other type of restoration.
- Cleans rivets and screws.
- Blending water guild on glass

(Both prep tools shown 50% of actual size)

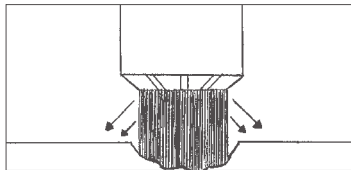

TOOL

The Detail Prep Tool gets into the smallest areas to completely clean the designated area. If you want to give this tool the ultimate test - clean a penny!

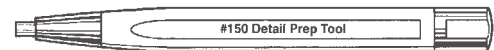

#150R REFILLS



SANDPAPER

It is very difficult for sandpaper to make direct contact with every little crack and crevice. It usually just does a superficial cleaning job.

Excellent For Spot Sanding and Paint Chip Repairs
It Will Become A Pinstriper & Touch-Up Man's Best Friend!



CAUTION: Glass fiber filaments can break during application, Keep the Detail Prep Tool away from your face, exposed skin and open cuts and sores. Always use protective gloves and eye wear when using this product.

A gotta have for any striper!



Actual Overall Length 6-1/4"



This gold ferrule capsule striper was made for traveling stripers. It is made of 100% blue squirrel and easily tucked into a pocket for stripers on the go. Available in 2 sizes.



SIZES	2107	1411
Trim Length	7/8"	1"
Capsule	3 1/2"	
Overall	6 1/4"	

Introducing . . . LAZER LINES

We are very excited to announce that Andrew Mack & Son Brush Company purchased Lazer Lines Brush Handles and Brush Heads by Robert Nouis, Jr. on March 3rd, 2008. This purchase only includes the Lazer Lines Brush Handles and Brush Heads. Lazer Lines products will be more accessible now that you can purchase the products through our regular distribution chain. We are very comfortable with the quality and service that we will be able to provide to the existing and new customer base of the line. All the product names will remain unchanged. The Handover brush head will be discontinued as soon as the limited stock is depleted. We have full intention to continue building the Lazer Lines offering with a few ideas already in the works! If you have any questions or concerns regarding Lazer Lines please do not hesitate to call us at 517-849-9272.

Sincerely,

Chris Fast

Andrew Mack & Son Brush Company



Polished Aluminum Brush Kit



Series #LL-PABK

This kit comes complete with chrome-embossed Lazer Line case. Set includes original medium striping handle, short handle, and your choice of single or double headed long handle. You also get your choice of two (2) different brush heads.

Limited Supply . . .

Anodized Aluminum Brush Kit

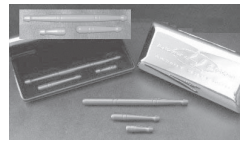

Series #LL-AABK

The Anodized Blue kits are the same high quality set as above, but the handles have a blue coating, and are sold in limited numbers. Set includes original medium striping handle, short handle, and your choice of single or double headed long handle. You also get your choice of three (3) different brush heads.

CUSTOM BRUSH HANDLES

Original Custom Handle



Series #LL-OCH

The Original Polished Aluminum Striping Handle - this is a 2- 1/4 inch polished aluminum striping handle, with a light, balanced feel and a smooth finish. Also available in Anodized Blue.

Short Polished Handle



Series #LL-SPH

A shorter handle for smaller hands, or for people who prefer that the handle not rest in the palm of the hand. You can easily turn this handle between your thumb and index finger. This handle works with all brush heads, but is especially good with the Lazer Line head. Also available in Anodized Blue.

Long Polished Single Handle



Series #LL-LPSH

Long Polished Single Handle. This is a very well balanced long handle for lettering and other activities where a quill, outliner, signature, scroll or pictorial brush head would be used.

Long Polished Double Handle

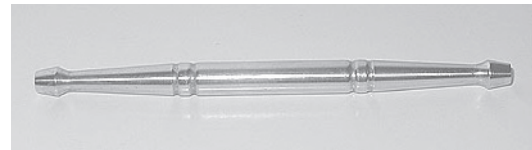

Series #LL-LPDH

Long Polished Double Handle. This handle is great for mobile sign painters and pinstripers! You can run it with two different brush heads for economy of use and helps prevent contamination of the hair when you are switching between brushes on small jobs. This is a very well balanced long handle for lettering and other activities where a quill, outliner, signature, scroll or pictorial brush head would be used. Also available in Anodized Blue.





CUSTOM STRIPING BRUSH HEADS



Series #LL-LLSBH

Lazer Line Striping Brush Head

Introducing the Lazer Line! These brushes have shorter hair and a full belly. They are excellent for fine straight lines and can hold a lot of paint. Available from size 000 to size 6. These work well with the short handle.

Sizes	000	00	0	1	2	4
-------	-----	----	---	---	---	---



Series #LL-B3

Lazer Line Brush 3

This is a great brush for design work and turns. Longer hair than the Original striper and less belly make for a very supple brush. Available in size 00 and size 0.

Sizes	00	0
-------	----	---



Series #LL-OSBH

Lazer Line Original Striping Brush Head

This is our original striping brush head. Designed for long straight lines, it has a full belly to hold a lot of paint, yet is still agile enough for turns and curves. A great all-around striping brush! Available in size 00, 0, and 1.

Sizes	00	0	1
-------	----	---	---



Series #LL-CB

Lazer Line Cabriolet Brushes

The Cabriolet is of the finest German squirrel hair in a shorter length. It's super versatile and is great for design work, turning corners as well as straight lines. Available in size 00, 0, and 1.

Sizes	00	0	1
-------	----	---	---



Series #LL-NFOSS

Lazer Line Nuclear Fall Out Synthetic Striper

Introducing Lazer Lines first synthetic striper! This brush is named well as it will withstand high winds and most types of environments. This brush is also made of Taklon hair. We chose this hair for our synthetic striper because the Taklon hair has performed so well with other brushes during product development! After using the Scarlet Fever for the first time, we knew this hair would make a great striper as it holds a lot of paint and seemingly appeared to hold up under all types of weather. If humidity and wind interfere with your striping, then you might want to give this brush a try! Available in size 000, 00, 0, and 1.

Sizes	000	00	0	1
-------	-----	----	---	---





CUSTOM LETTERING & SCROLL BRUSH HEADS



Series #LL-BP

Lazer Line Black Plague

The Black Plague is simply the coolest scroll brush available! Black Chrome ferrule with taklon hair, available in 5 sizes.

Sizes	000	00	0	1	2	3
-------	-----	----	---	---	---	---



Series #LL-SF

Lazer Line Scarlet Fever

Made from the same hair as our Black Plague, but extended to enable smooth long swirls - without the need for excessive re-loading! This hair provides the artist exquisite control! This brush is great for swirls and even out-lining larger lettering. Robert has found many uses for the unique brush and we're sure you will too! With 5 different ferrule sizes/widths and 2 lengths, you gotta have them all to complete your arsenal!

Sizes	1	2	3	4	5
-------	---	---	---	---	---



Series #LL-GB

Lazer Line The Golden Boys

Introducing one of our latest brushes... a "speed flat" with the same great Taklon hair as some of our other brushes. We have fallen into a "gold mine" with this hair. The Golden Boys are great for lettering and fill work. We offer 4 distinctive sizes ranging from 3/16" - 1/2" ferrule size and all at 1-3/4" hair length. These brushes hold a lot of paint and have great control. We have found this brush to be useful in laying down sizing when preparing for gold/and/or silver leafing. It allows the sizing to glide smoothly onto the surface. It withstands the harsher chemicals and cleansers better than natural hair brushes.



Series #LL-GC

Lazer Line The Golden Child

This brush has all the same characteristics of the Golden Boy except for the hair length. The shorter hair length of 7/8" comes in all four sizes.

Sizes	3/16"	1/4"	3/8"	1/2"
-------	-------	------	------	------



Series #LL-GWE

Lazer Line Green With Envy

This extended quill is also made of the same fine Taklon hair as the other brushes in our collection! This brush comes in 5 different sizes and is made very similar to the Scarlet Fever, except this brush has a blunt end! Green With Envy is great for lettering as it has a lot of spring. We've found that some of our product testers have made great use of this brush with its many different painting applications.

Sizes	1	2	3	4	5
-------	---	---	---	---	---



Series #LL-LQ

Lazer Line Quill

This quill is an exact duplication of our series #169 quills, except without the handle. The hair that is used is a black synthetic and blue squirrel hair mixture.



Sizes	0	1	2	3	4	6	8	10
-------	---	---	---	---	---	---	---	----

Series #169 Quills

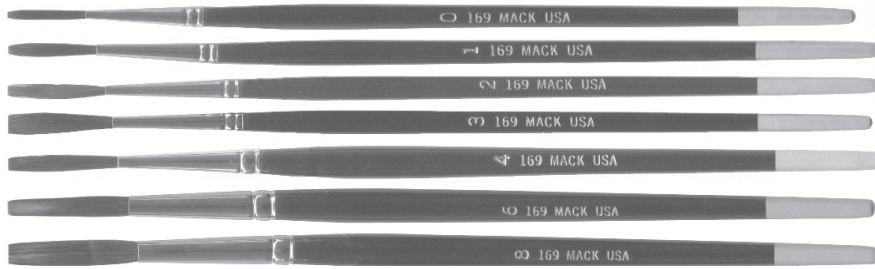

Sizes	0	1	2	3	4	5	6	8	10
-------	---	---	---	---	---	---	---	---	----

This quill was produced as cost alternative to the traditional German quills. The erosion of the dollar versus the euro has inflated the price of our quills in the last few years. We decided it was time to produce an American made nickel plated ferrule quill to give the painter another cost conscious choice. The traditional quill will always have a place in the sign painter's kit. The hair that is used in the series #169 is a black synthetic and blue squirrel hair mix as opposed to the German quill that is made of pure squirrel hair. We have had great success in recent years with this particular mixture of hair. The quill has



Monster Stix by Jeral Tidwell

After more than a year of development, we are super stoked to have a hand full of the coolest and most versatile paint brushes we have ever offered. For this set, Jeral consulted with one of the most well rounded painters he has ever know... his wife Sarah. With her input, the set was elevated to a whole new level. This 7 pc. set is the next step in our collective painting evolution. Long lines, tiny details, smooth shading, and just plain ole rocking it out... these bad boys have got you covered.

Series M/T - Monster Stix

M/T Name	Full Set	Better Half	Shady	Big Filly	Foxy	Lil' Filly	Super Slim	Monkey Whisker
----------	----------	-------------	-------	-----------	------	------------	------------	----------------



Series M/T (Mack/Tidwell) Brushes

Mack/Tidwell brushes? Why? Well, I didn't set out to reinvent the wheel, however, I wanted to make a brush set for other artists like myself... illustrators who work in a few mediums. When you're working on finks, eyeballs, monsters, etc... these brushes will prove themselves invaluable. The purpose of the set is to make all of your detail work faster and easier... plain and simple. These brushes work great with enamels, acrylics, oils, and I'm sure they will work with just about any other medium. The handles are a little fatter in the belly (*where you grab 'em*) so they have a little more room for normal size hands (*see the picture for a good idea... it's not much, but I like to think it's just enough*). The bristles vary depending

on the brush size and configuration. The smaller brushes are made of a softer fine quality synthetic, the large flat and the long outliner are made with golden synthetic. I chose synthetic because these brushes are much easier to care for and keep their shape extremely well. Both types of bristles have smooth paint delivery while keeping a little spring to them. All of the brushes are super useful and you will find yourself reaching for them in a hundred different situations. They blend paint really well without the brush strokes of stiffer bristles. They also work for lines, shading, and for sharp detail. The brushes really speak for themselves. There are a couple of other brushes that the set needs so we are working on those now. I know there is no perfect brush or brush set for everyone but, I seriously doubt you'll find a more useful brush set at this price point or any for that matter. Not to mention, they are the only brushes on earth with brass knuckles stamped on the handles!

Jeral Tidwell

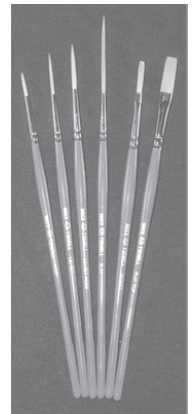

AVAILABLE IN OPEN STOCK

OR AS A 3-PC.
OR 6-PC. SET

	6-pc. Set					
Sizes/Description	Flat Top 1/4"	Lil' Bit #1	Lil' Bit More #4	Mini	Skinny 1/8"	Slim

	3-pc. Set		
Sizes/Description	Five Speed #5	Heavy #6	One-Liner #1

6 brushes... worth losing a finger over!
Seriously... they are that good!

These have synthetic bristles and can be used with 1-shot, acrylics, oils, and any other paint you can dream up... trust me, I have tried it.

- MULLET** - Long bristles, 1/4 flat that is Great for lettering, filling, etc...
Series #M/T - Mullet
- SCRUBBY** - Short bristles, 1/4 flat blender and all around useful brush.
Series #M/T - Scrubby
- SCRIPTY** - Long bristles, square lettering brush with a million uses.
Series #M/T - Scripty
- PICK UP LINE** - Long sharp bristles, this is an Amazing outliner.
Series #M/T - Pick Up Line
- POINTY** - Super fine detail brush and outliner... I use it for everything.
Series #M/T - Pointy
- STUBBY** - This is basically a #2 round with infinite uses.
Series #M/T - Stubby



BROKEN PINKIES

This set is basically all of the brushes missing from my last 2 brush sets. I am always finding a reason to add brushes to my box and these took me almost 2 years to develop and perfect... not to mention that they are **FLUORESCENT PINK!**
What else could you ask for?!?

Brush Boxes

The all metal brush box will protect your brushes while drying, storing, & transporting.
The brushes are held in place with steel spring coils.



#99 Brush Box

The all aluminum brush box will protect your brushes while drying, storing and transporting. This kit has four trays for storage and four latches that are secured with one key lock.

Dimensions – 18" X 10.5" X 12"
Series BB-99

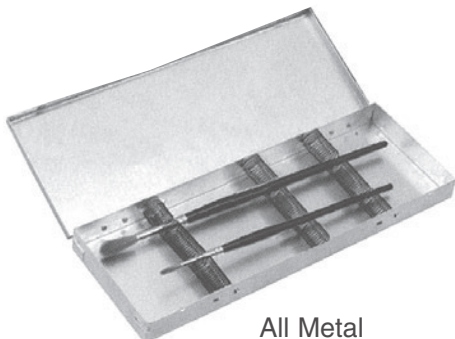

All Metal
#62 Brush Box 5" x 15"
with 3 springs
SERIES BB-62

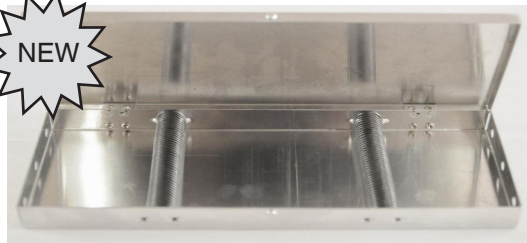

#46 Brush Box 3 1/2" X 10"
Series BB-46

The all aluminum brush box will protect your brushes while drying, storing, and transporting. The brushes are held in place with two steel spring coils.

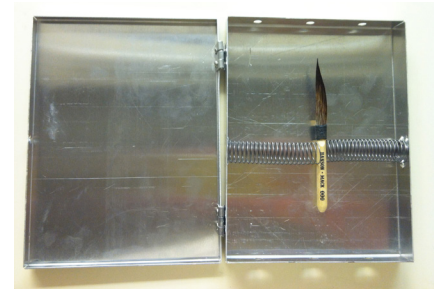

#31 Brush Box 5" x 6 1/2"
with 1 spring (for sword stripers)
SERIES BB-31 Brush Box

ALL PURPOSE THROW-AWAY "WHITEY II"

SERIES 2001 WOOD HANDLE WITH HOLE

PURE NATURAL WHITE BRISTLE
PAINT REMOVER, STRIPPER, SPREADING RESINS, VARNISH, UTILITY, CHIP, PARTS CLEANING AND EPOXY BRUSH
SIZES: 1/2" – 1" – 1-1/2" – 2" – 2-1/2" – 3"
4" Single Thick (3/8" thick)

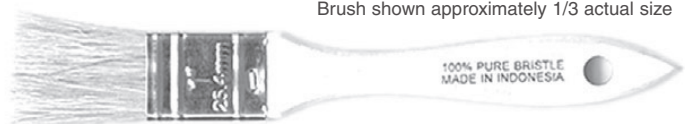

Brush shown approximately 1/3 actual size



"WHITEY II"

2001-B
Box
Assortment

Contents:

- 1/2 Doz. - 1/2" • 1 Doz. - 1"
- 1 Doz. - 1-1/2" • 1 Doz. - 2"
- 4 Only - 2-1/2" • 8 Only - 3"
- 4 Only - 4" (Single Thick 3/8")

The quantities in this assortment are only a suggestion. If you wish a different size, we will be happy to put it together for you. We would ask that you keep your total quantities at around 60 pieces, so that the brushes will fit in this standard display box.

SERIES 1930

Fine watercolor brushes - pure camel hair; metal ferrules on lacquered handles (each size has a different color handle). Guaranteed setting acetone resistant; packed in unique circular transparent acetate box.

1 Gross Assorted Sizes 1 to 6
2 Dozen Each Size

Also available in Open Stock Series 1930/OS
(All Open Stock brushes have wooden polished handles.)
Open Stock Also Available in Size #7



"Great Touch Up Brushes" Box Assortment No. B-100

FORMERLY #50



Fine watercolor brushes - pure camel hair; metal ferrules on lacquered handles (each size has a different color handle). Guaranteed setting acetone resistant; packed in unique circular transparent acetate box.

The brushes in the B-100 assortment are slightly larger than the brushes in the 1930 assortment

No. B-100
1 Gross Assorted Sizes 1 to 6
2 Dozen Each Size

Also available in Open Stock Series 1930/OS
(All Open Stock brushes have wooden polished handles.)
Open Stock Also Available in Size #7

#16 Touch-Up Scraper



This is a camel hair touch-up brush with a flat edged end that can be used to scrap product. The brush has a ferrule diameter of a 1/8" and a hair length of 1/2". The overall length of the brush is 4 7/8". The handle is black plastic.

Sometimes foreign manufacturers put "sizing" in the brushes to make them pointed. This is usually done with corn starch or sugar water and is easily removed with warm or hot water.

QUALITY BRUSHES FOR THE SIGN PAINTER

● Brown Quills ● Grey Quills ● One Stroke Lettering ● Outliners

If you are now selling *One Shot, House of Kolor, Ronan, Kustom Shop, DuPont Hot Hues Pinstripe Efx, Xotic or Alsa* then you definitely need one of our brush displays to complete the circle.



Display can be used
on counter or hung on
peg board

11" High
8-1/2" Wide
7-1/2" Deep



These assortments are only suggestions,
feel free to make up your own assortment.

SIGN BRUSH ASSORTMENT

Series SBA-15

SERIES 179L - BROWN QUILL/RED HANDLE
3 each sizes, 2, 3, 4, 5, 6, 8
2 each size 10, 12

Also available in sizes 0, 1, 7, 9, 11, 14, 16, 18, 20

SERIES 189L - GREY QUILL/BLACK HANDLE
3 each sizes 2, 4, 6, 8

Also available in 0, 1, 3, 5, 7, 9, 10, 12

SERIES 1962 - ONE STROKE LETTERING
2 each sizes 1/4" - 1/2" - 5/8"

Also available in sizes 0, 1, 3, 5, 7, 9, 10, 11, 12

SIGN BRUSH ASSORTMENT

Series SBA-18

Exactly the same contents as SBA-15

PLUS

2 each sizes 2, 4, 6 series 839, Squirrel/Ox Outliners
(Also available in sizes 1, 3, 5)

The 4 most important brushes your customer needs when using a lettering enamel are: **1.** Mack Striping Brushes, **2.** Brown and Grey Quills, **3.** One Stroke (Flat) Lettering Brushes, **4.** Outliners. You are already selling our Mack Striping and Touch-Up Brushes which we hope are being featured and displayed on our NO CHARGE sales display. Now, you should seriously consider these other important brushes. Per square feet of sales, this could be the most profitable square foot in a store. HIGH TURNOVER - GOOD PROFIT MARGIN - REQUIRES LIMITED SPACE. We have given you a couple of suggestions for starter assortments, if you wish another mix of brushes, just let us know what you want. There is a label on the back of the display showing what the original quantities were and what other sizes are available. This will be invaluable in helping control your inventory.

LETTERING QUILLS

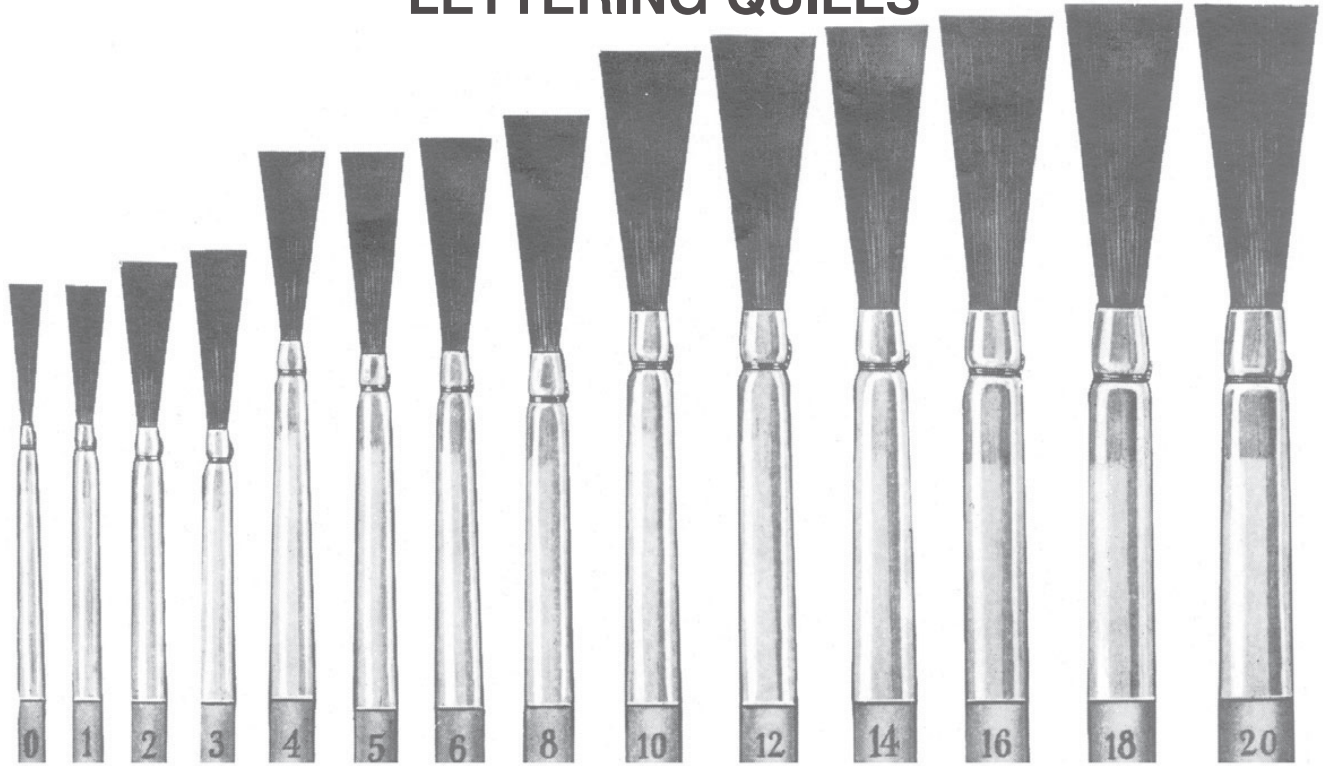

Sizes 7, 9, 11, 22, 24, 26 & 30 Not Shown - But Available

0	1	2	3	4	5	6	7	8	9	10	11	12	14	16	18	20	22	24	26	30
11/16"	3/4"	7/8"	15/16"	1"	1-1/16"	1-1/8"	1-3/16"	1-1/4"	1-5/16"	1-3/8"	1-7/16"	1-1/2"	1-1/2"	1-9/16"	1-9/16"	1-5/8"	1-5/8"	1-5/8"	1-11/16"	1-13/16"

FINEST BROWN (KAZAN SQUIRREL HAIR) LETTERING QUILLS WITH ATTACHED HANDLES

GRADUATED HAIR LENGTHS (Other Lengths Not Available)

SERIES 179 Brown (Kazan) Quill With Attached Plain Wood Handles.

SERIES 179L Brown (Kazan) Quill With Attached Red Lacquered Handle.

SIZES 0 TO 20
SIZES 0 TO 30

This brown quill is handmade in Germany by highly specialized brush makers. This lettering quill is essential for every sign painter. The brown quill is best suited for smooth surfaces such as: glass or automotive surfaces. The brown quill is a little softer than the grey quill.

GREY (TALAHOUTKY) LETTERING QUILL WITH ATTACHED HANDLE

0	1	2	3	4	5	6	7	8	9	10	11	12	14	16	18	20
11/16"	3/4"	7/8"	15/16"	1"	1-1/16"	1-1/8"	1-3/16"	1-1/4"	1-5/16"	1-3/8"	1-7/16"	1-1/2"	1-1/2"	1-9/16"	1-9/16"	1-9/16"

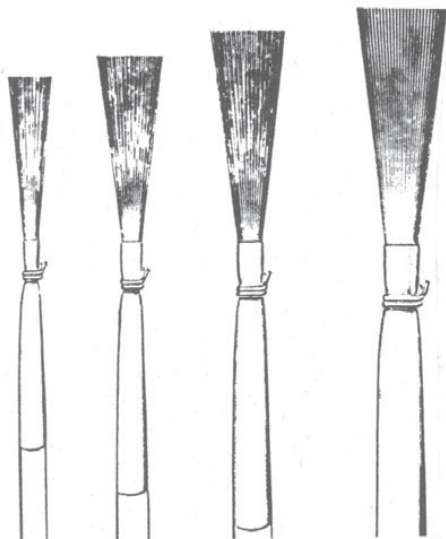

SERIES 189 Grey (Talahoutky) Lettering Quill
With Attached Plain Wood Handle.
SIZES 0-12

SERIES 189L Grey (Talahoutky) Lettering Quill
With Attached Black Lacquered Handle.
SIZES 0-20

This grey quill is handmade in Germany and it is equally as important as the brown as an essential brush for the sign painter. The series 189 or 189L is a universal lettering brush. The grey hair has more snap than the brown. It is used for general commercial work such as: signs, truck lettering, boats, etc. The grey hair is more durable than the brown, and this brush is suitable for lettering on most surfaces.

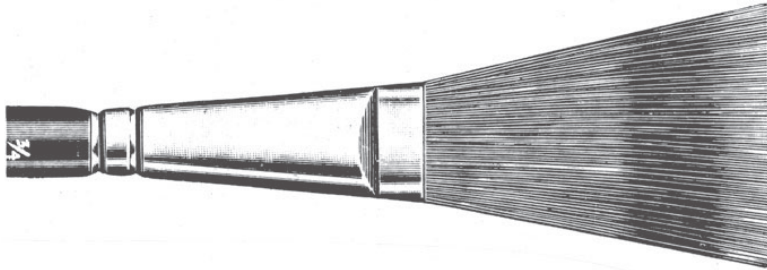
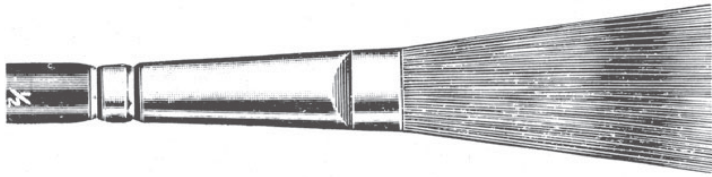
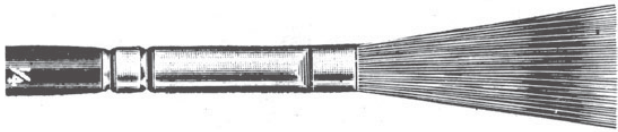

Jet Stroke Truck Letterer SERIES 1962

Pure Squirrel-Black Ox Mixture

•••
Long Length
Seamless Nickel Ferrules
Dark Brown Handles
One Stroke Lettering

The SERIES 1962 is an excellent overall lettering brush. It is normally used for larger lettering and production lettering. It can also be used as a fill-in brush and an outliner for large letters. The long hair length allows the brush to carry a lot of paint. This brush is suitable for most surfaces. It is a mixture of pure squirrel and black ox. It has a flat ferrule and the hair comes in graduated lengths.

Sizes	1/8"	1/4"	3/8"	1/2"	5/8"	3/4"	1"	1-1/4"	1-1/2"
Hair Lengths	1-3/16"	1-3/8"	1-1/2"	1-5/8"	1-11/16"	1-3/4"	1-15/16"	1-15/16"	2"

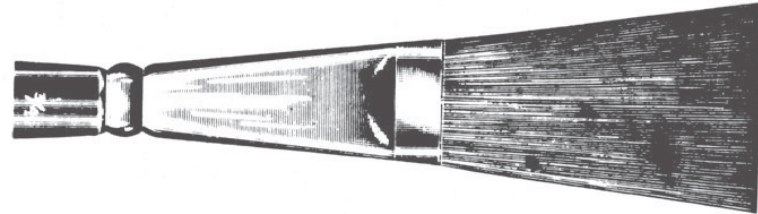
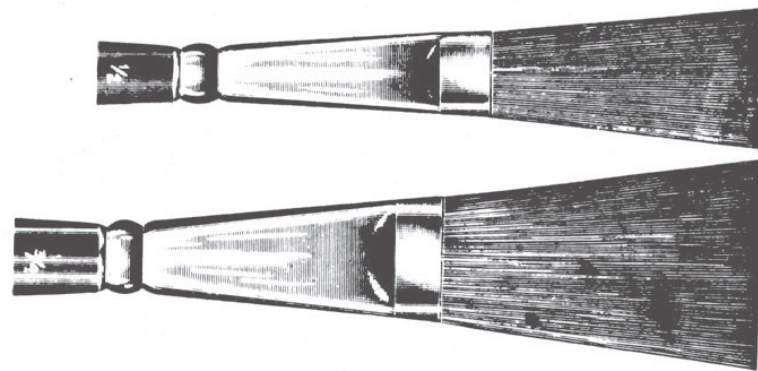

Superior Lettering Brush Soft Flat Stroke SERIES 1992

100% Pure Blue Squirrel Hair

•••
Seamless Nickel Ferrules
Black Polished Handles

This Soft Flat has a very clean edge with excellent control. You can letter very quickly and it lays out paint beautifully.

Sizes	1/8"	1/4"	3/8"	1/2"	5/8"	3/4"	1"
Hair Lengths	1-3/16"	1-3/8"	1-1/2"	1-5/8"	1-11/16"	1-3/4"	1-15/16"

Mack Grey Stroke Lettering Brush Series 1932



(1/4" Actual Overall Length 8")



(5/8" Actual Overall Length 9")

The old "Art Sign Company" used to make a series 1963 Super Grey Hound. It was made with Pure Grey Talahoutky Squirrel. This Grey Squirrel is very hard to get today and is also very expensive. Nevertheless, our customers have been requesting a Grey Squirrel Flat (or lettering brush). Since our 1962 (Flat), which is a mixture of Pure Blue Squirrel and Ox hair sells as well, or even a little better, than our Pure Squirrel Flat series 1992 - we thought we would bring out a Grey mixture Flat that would not be all that expensive and still give you the body and snap of Grey Squirrel Hair. This is not intended to replace our Series 1962 or 1992. It is a merely a less expensive alternative. Hope you like it!!

Sizes	1/8"	1/4"	3/8"	1/2"	5/8"	3/4"	1"
Lengths	1-5/16"	1-3/8"	1-1/2"	1-5/8"	1-11/16"	1-3/4"	1-15/16"

Graduated Hair Lengths

OUTLINERS — HIGHLIGHTERS

Outliners

TOP QUALITY

**BLACK SYNTHETIC
AND GOAT MIXTURE**

SERIES 838

Nickel Ferrules
Plain Varnished Handles

Sizes	1	2
Hair Length	1-1/16"	1-1/8"

3	4	5	6
1 1/4"	1-3/8"	1-1/2"	1-9/16"

Hair is very strong, but will not hold as much paint as our SERIES 839 Outliner.

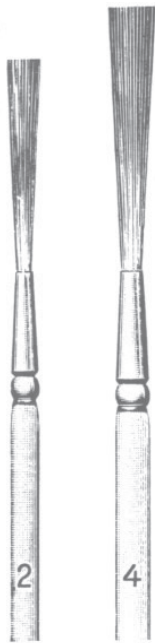

Outliners

FINEST QUALITY

**PURE BLUE
SQUIRREL HAIR**

SERIES 839

Seamless Nickel Ferrules
Black Handles With Gold Tips

Sizes	0	1	2
Hair Length	1"	1-1/16"	1-1/8"

3	4	5	6
1 1/4"	1-3/8"	1-1/2"	1-9/16"

Our 839 is much softer than our 838 outliner & will carry more paint.

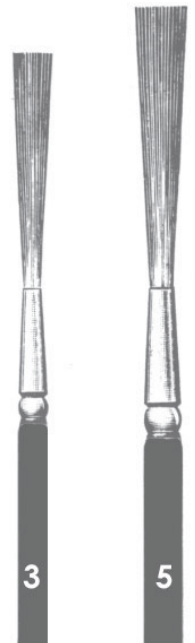

SERIES 838/839 OUTLINER

This brush is used for outlining letters, for scroll work, and applicable sign work. The Series 838/839 is suitable for most surfaces. It has a round ferrule and graduated hair lengths.

Series #840 Outliner



Actual Overall Length 8"

SIZES	4/0	2/0	0	2	4
Length Out	1"	1-1/8"	1-3/8"	1-5/8"	1-3/4"

The #840 outliner is made with synthetic squirrel hair. This is a new synthetic that gives you the benefits of a natural haired brush. It is a soft hair that holds a lot of paint and gives you good snap.

Red Sable Lettering and Showcard Brush

SERIES 818

Nickel Ferrules
Black Polished Handles

"Round European Dressed Red Sable Brush For Lettering With Perfect Square Edge."

Pure red sable hair has more spring and is more flexible than our quills & outliners. After painting it returns easily to its initial shape. Red sable is more durable than squirrel. This lettering brush is shorter in hair length than our quills or outliners, therefore, you will have much more control. However, red sable is not as soft as squirrel and will not carry as much paint.

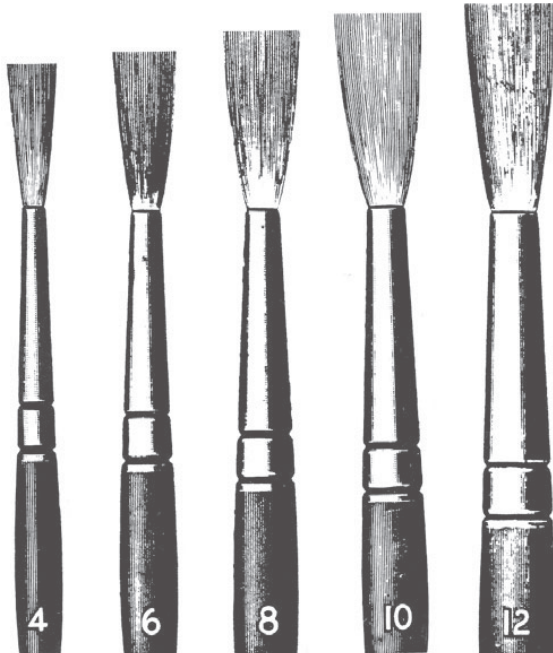

Sizes	2	4	6	8	10	12	14	16
Hair Lengths	2-1/32"	3/4"	7/8"	15/16"	1"	1-1/8"	1-3/16"	1-1/4"

LINERS — SCRIPT — RIGGERS

(Fine Accurate Lines For Light Scroll or Signature Work)

PURE KOLINSKY SABLE SCRIPT BRUSH (Extra Fine)



SERIES 127
Polished Handles
Nickel Ferrules

Script Brush - Pure European Dressed Red Sable
Excellent for Fine Line, Scroll Work,
Signwriting, Ceramics and China Painting

Sizes:	1	2	3	4	5	6
Lengths:	11/16"	3/4"	13/16"	7/8"	15/16"	1"

RED SABLE DRESDEN LINERS

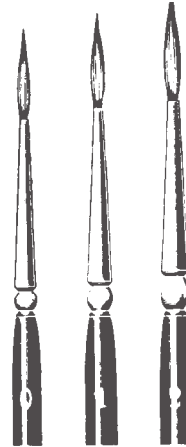

SERIES 522
Polished Handles

Script (Dresden-Liners) — Nickel Ferrules
Pure European Dressed Red Sable
Excellent for Fine Line, Scroll Work,
Signwriting, Ceramics and China Painting

Sizes:	00	0	1
Lengths:	3/8"	9/16"	5/8"

PURE RED SABLE LINERS



SERIES 126
Polished Handles
Pure European Dressed Red Sable
Nickel Ferrules

Script (Long Stock) Liners
Excellent for Fine Line, Scroll Work,
Signwriting, Ceramics and China Painting

Sizes:	1	2	4	6
Lengths:	7/8"	15/16"	11/16"	1-3/16"

BROWN OX HAIR SIGNWRITERS

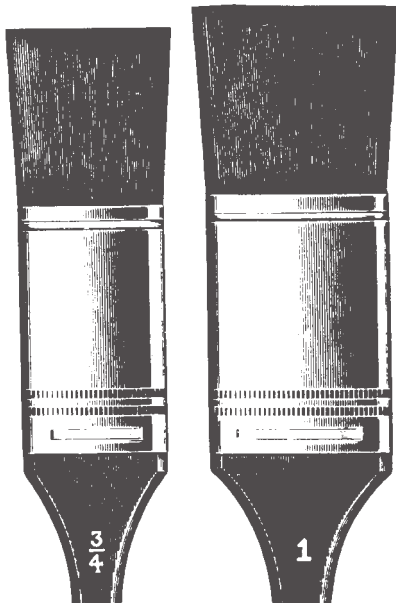

SERIES 175
SIGNWRITERS
Ox Hair
Nickel Ferrules
Cup and Chiseled
Red Handles
Finest Grade

Sizes:	1/4"	1/2"
Lengths:	3/4"	15/16"
	3/4"	1"
	1-1/16"	1-1/4"



SYNTHETIC WHITE TAKLON RIGGER

SERIES 258
Outlining and Script can be done
easily with this Rigger
Black Polished Handles
Seamless Nickel Ferrules

Synthetic White Taklon has the same
snap and lettering qualities as sable,
but at a considerably lower price.

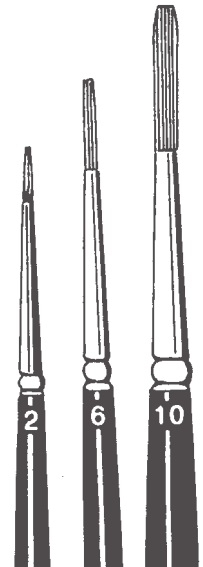

Sizes:	1	2	4	6	8	10
Lengths:	1/4"	5/16"	7/16"	9/16"	11/16"	13/16"

RED SABLE ARTIST BRUSHES

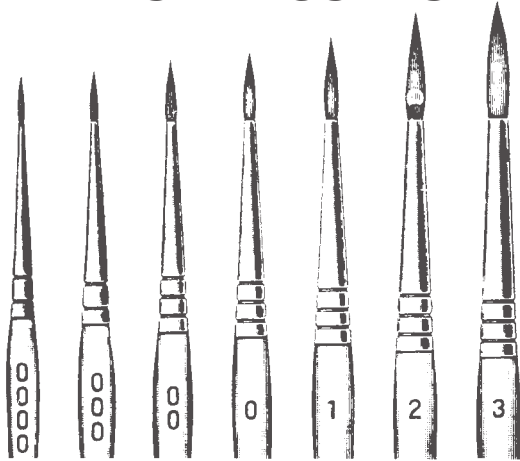

OUR BEST RED SABLE BRUSH PERMA POINT SERIES 520

European Dressed Red Sable Spotting Brushes
Seamless Nickel Ferrules on Polished Handles

SIZES:

5/0 - 4/0 - 3/0 - 2/0
0 - 1 - 2 - 3

THE NEEDLE-FINE POINT AND EXTRA SMALL
SIZES ARE DESIGNED FOR MINUTE DETAIL
WORK BY RETOUCHERS, CERAMISTS,
HOBBYISTS, ETC.

Excellent for Fine Detail Work

RED SABLE WATERCOLOR BRUSHES

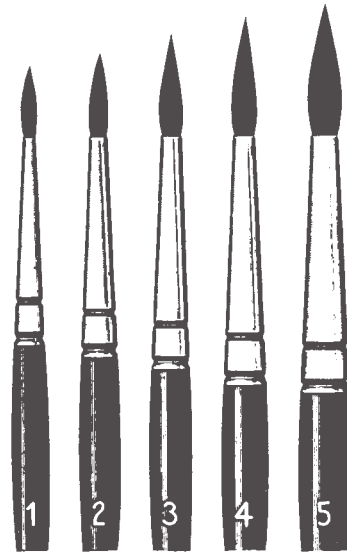

THE "ECONOMY" SERIES 536

Chinese Dressed Red Sable, Good Quality

Seamless Nickel Ferrules, Black Handles

SIZES:

3/0 - 2/0 - 0 - 1 - 2
3 - 4 - 5 - 6 - 7 - 8

CAMEL HAIR WATERCOLOR BRUSHES

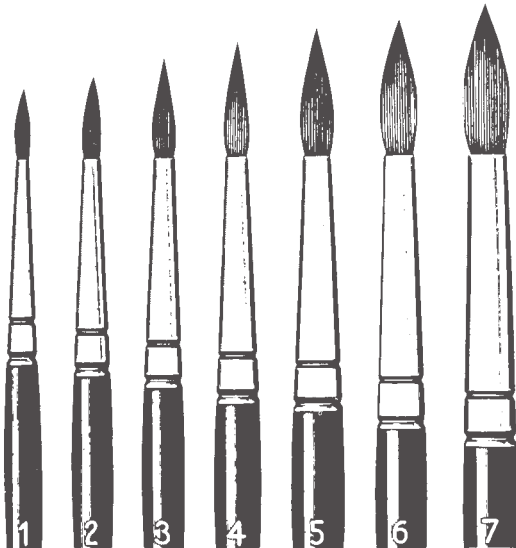

SERIES 970

Camel Hair Watercolor Brush
Tin Ferrules — Blue Handles
Nickel Ferrules - Fine Grade Pony Hair

SIZES:

3/0 - 0 - 1 - 2 - 3 - 4 - 5 - 6 - 7 - 8 - 9 - 10 - 11 - 12

Our series 1127 has been replaced with our series 970. They are virtually the same brush.

The Series 1120 Watercolor Brush has been discontinued

White Hog Bristle Cutters

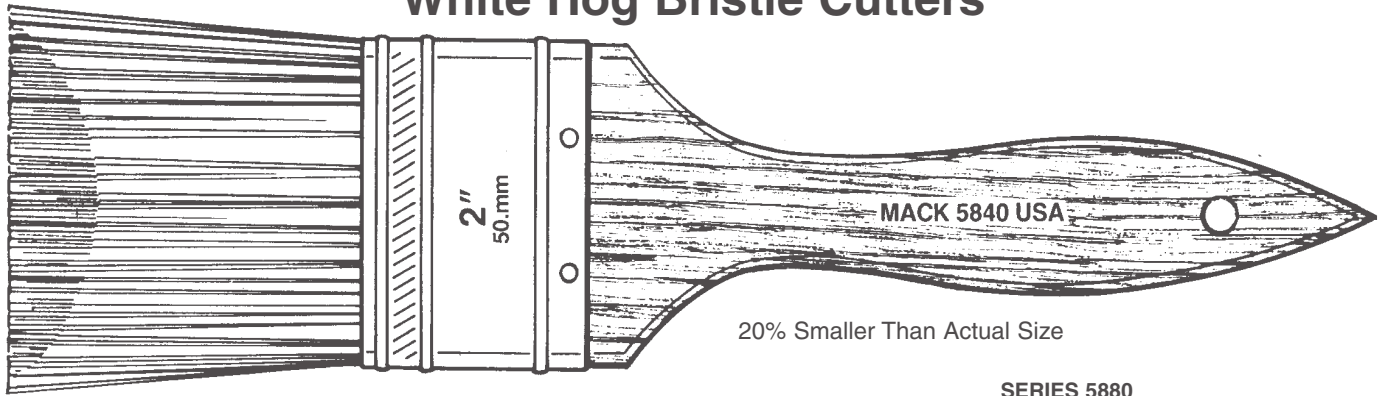

20% Smaller Than Actual Size

SERIES 5840 (Single Cutter)

Fine Quality - Clear Lacquer Finished Handles
Nickel Ferrules - Hand Chiseled
Pure White Hog Bristle - For Outdoor Work

Size	1"	1-1/2"	2"	2-1/2"	3"
Length (trim)	1-7/8"	2-1/8"	2-3/8"	2-3/8"	2-3/4"
Thickness	5/16"	5/16"	5/16"	5/16"	3/8"

SERIES 5880 (Double Cutter)

Fine Quality - Clear Lacquer Finished Handles
Nickel Ferrules - Standard Production Chiseled
Round "Peg Grip" Handle With Hole
Pure White Hog Bristle - For Outdoor Work

Size	1"	1-1/2"	2"	2-1/2"	3"
Length (trim)	1-7/8"	2-3/8"	2-5/8"	2-7/8"	3-1/8"
Thickness	7/16"	1/2"	9/16"	5/8"	11/16"

LETTERING - ONE STROKE SIGNWRITER

SERIES 160 SABELINE-ONE STROKE

Finest Grade
Finest Selected Sabeline Hair
Nickel Ferrules
Polished Handles

Size	1/8"	1/4"
Length	11/16"	13/16"
	1/2"	3/4"
	1-1/16"	1-1/4"
		1-1/2"

SERIES 160 SABELINE-ONE STROKE

This is a stroke or lettering brush that is normally used for bigger show card and lettering work. The brush is suitable for most any surface. Because of the sable hair in the brush, it has a lot of snap and makes a nice straight razor edge. It is made with sabeline hair and has a flat ferrule.

GOLDEN TAKLON ONE STROKE LETTERING

SERIES 162
Sharpest Working Edge
Seamless Nickel Ferrules
Black Handles
Synthetic Nylon Filament

Size	1/4"	1/2"	3/4"	1"
Length	13/16"	1-1/16"	1-1/4"	1-1/2"

Synthetic Golden Taklon has the same snap and lettering qualities as Sable, but at a considerably lower price.

4080 Rhino Straight End Fitch

Actual Overall Length 12-1/2"

4080 1 MACK RHINO USA

4085 Rhino Angular Fitch

Actual Overall Length 12-1/2"

4085 3/4 MACK RHINO USA

"The Rhino Fitch was developed to have the softness to paint on smooth surfaces, hold a good amount of paint, keep their snap, but have the stiffness to work on rough surfaces such as coating sandblasted signs, wall lettering and pictorials. They are great for blending, lettering, stippling, faux finishes, cutting clean lines and pictorial painting on any surface. True to its namesake this brush is tough and durable."

SIZES 1/4" 3/8" 1/2" 3/4" 1" 1-1/4"

— Gary Anderson
Bloomington Design

FITCHES

MASTERSTROKE BRISTLE FITCH

(Longer Length)

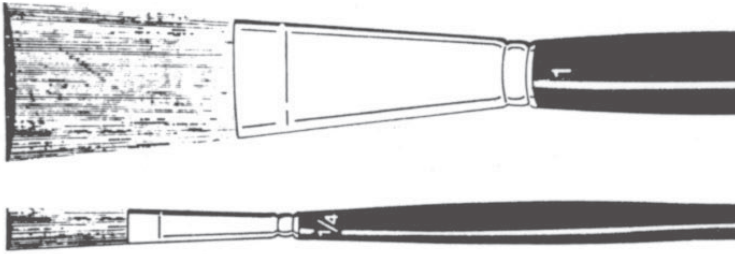

Brushes shown approximately 3/4 actual size

SERIES 4055

Finest 100% White Hog Bristle

Cup Chiseled

Seamless Nickel Ferrules

Long Plain Polished Handle

Size	1/4"	1/2"	3/4"	1"	1-1/2"	2"	2-1/2"
Length	7/8"	1-1/16"	1-7/16"	1-5/8"	2"	2-1/8"	2-1/4"

This white bristle fitch (100% pure white hog bristle) is cup chiseled to a straight edge and also has a long polished handle. This is a lettering brush, but because the bristles are longer than the Series 4042, it can also be used for outlining. This brush is best suited for outdoor work (walls, bulletins and rough surfaces).

WHITE BRISTLE FITCH by David Hightower

(Shorter Length)

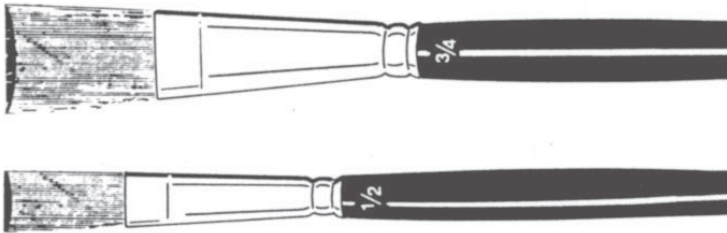

Brushes shown approximately 3/4 actual size

SERIES 4042

Finest 100% White Hog Bristle

Cup Chiseled

Seamless Nickel Ferrules

Long Polished Red Handle

Size	1/4"	1/2"	3/4"	1"
Length	9/16"	3/4"	1"	1-3/16"

This white bristle fitch (100% pure white hog bristle) is cup chiseled to a straight edge and has a long polished handle. It is a lettering brush best suited for outdoor work (walls, bulletins and rough surfaces).

ANGULAR FITCH LINER



Brushes shown approximately 3/4 actual size

SERIES 4090

Finest 100% White Hog Bristle

Seamless Nickel Ferrules

Long Blue Varnished Handle

Size	1/4"	1/2"	3/4"	1"
Length	1/2"	3/4"	1"	1-1/4"

This angular fitch is good for awning work. Sign painters also find it easier to use an angular brush when working on a wall or upright surface. It is good for outdoor work (awnings, walls, bulletins and rough surfaces). This brush is not chiseled. There is no advantage to chisel an angular liner, since most sign painters want an even down stroke.

SOFT HAIR FITCH

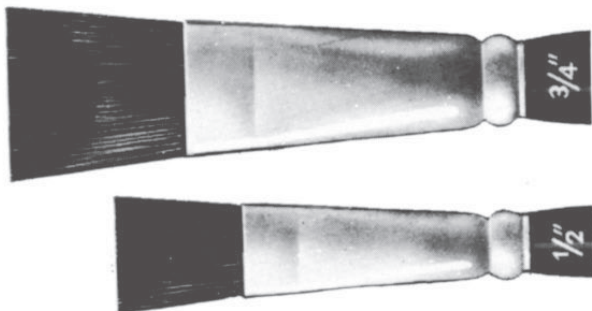

SERIES 4031

Russian Sable Hair

Seamless Nickel Ferrules

Long Gold Handle With Black Tip

Square End - Hand Cupped To A Sharp Chiseled Edge

Size	1/4"	1/2"	3/4"	1"
Length	1/2"	5/8"	15/16"	1-1/16"

One of the most important brushes for the professional sign painter. This soft hair fitch is constructed with premium materials to provide excellent handling qualities. Used in lettering paints for layout, outlining, pictorial & tight work.

SOFT HAIR ANGULAR FITCH

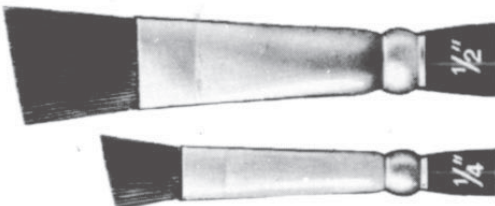

SERIES 4039

Russian Sable Hair

Seamless Nickel Ferrules

Long Gold Handle With Black Tip

Angular Chiseled Edge

Size	1/4"	1/2"	3/4"	1"
Length	1/2"	5/8"	15/16"	1-1/16"

Companion to the 4031, built to identical standards, but shaped with an angular chiseled edge for those who prefer to work with a sharper point.

Brushes For Water Borne, Waterbase and Acrylic Paints

The specific density of water borne or water base paint is much heavier than lacquers & enamels. It is therefore necessary to use a brush with a little more body. Pure squirrel hair is fine for the lacquers & enamels, but a little too soft for the higher density water borne paints. We have developed a brush with a squirrel and taklon mixture to give you the desired hair weight for water borne paints.



Size	0	1	2	4	5	6	8	10	12
Length Out (trim)	11/16"	3/4"	7/8"	1"	1-1/16"	1-1/8"	1-3/16"	1-5/16"	1-3/8"

LETTERING QUILLS

SERIES 2179: Brown Synthetic Squirrel Mixture

Our preferred mixtures for waterbase & acrylic paint.



Size	1/8"	1/4"	3/8"	1/2"	5/8"	3/4"	1"
Length Out (trim)	1-1/8"	1-1/4"	1-3/8"	1-1/2"	1-5/8"	1-3/4"	1-7/8"

SERIES 2962 ONE STROKE

Brown Synthetic Squirrel Mixture

Our preferred mixtures for waterbase & acrylic paint.

SERIES 2838 OUTLINERS

Brown Synthetic Squirrel Mixture

Our preferred mixtures for waterbase & acrylic paint.

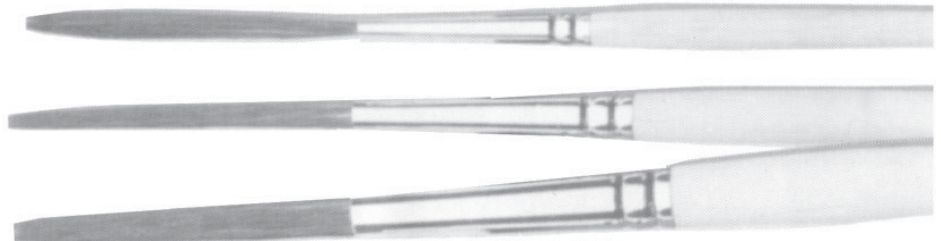

Available in Sizes: 00 0 1 2 3 4 6
Length Out or Trim on ALL Sizes is 1-11/16"

CAMEL HAIR LACQUERING BRUSH

SERIES 5170 (FINE GRADE)

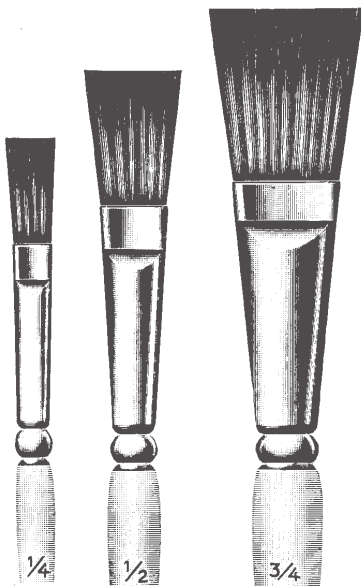

**CAMEL HAIR
(TOUCH-UP)
LACQUERING BRUSH**

Blend of Pony & Goat Hair
Aluminum Ferrules
Plain Varnished Handles

OPEN STOCK SIZES:

1/16" - 1/8" - 1/4" - 3/8" - 1/2"
5/8" - 3/4" - 1"

CAMEL HAIR FLATS

SERIES 49 - Formerly 9305

Blue Wood Handles - Aluminum Ferrules
Sizes: 1/8" - 1/4" - 3/8" - 1/2" - 5/8" - 3/4" - 1"



Overall length of 1/2" brush = 8"

BOOKS

SIGN PAINTING - LETTERING - PINSTRIPING - DESIGN



FREEHAND LETTERING
by Dick Bird **Series FL**
Richly illustrated with many demonstration photos, charts, alphabets and trade secrets. This carefully written book by a master craftsman with a lettering brush gives your customers a professional insight into the life of a lettering artist as well as guiding them through techniques, letterstyles, brushes, paints and supplies.

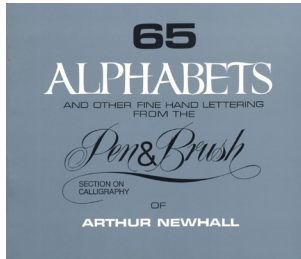

65 ALPHABETS
Hand-lettered beauties
108 pages, 7 1/4-by-8 1/2
Series 65A

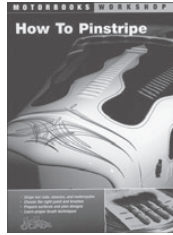

HOW TO PINSTRIP
Everything you need to know to get started, to further your mastery of the form, or to simply understand how a good design comes together. Step-by-step guide to the pinstripping process. Illustrated with color photography throughout, How to Pinstripe is the perfect source for beginners and veterans alike.

Series HTP

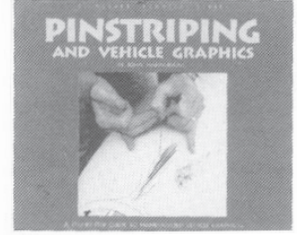

PINSTRIPPING AND VEHICLE GRAPHICS
by John Hannukaine
This book guides you through a basic pinstripping and a simple long-line project, and covers the skills you need to create your own unique designs. It also features step-by-step color photos that detail splatter and dry brush effects, sponge-applied graphics, cartoons and much more. **Series P & VG**

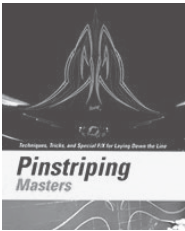

PINSTRIPPING MASTERS **Book One & Two**
A fresh and innovative book on pinstripping, *Pinstripping Masters* features 28 top pros offering step-by-step instruction, tricks and techniques of the trade. In addition to the how-to section is an awesome gallery of striped projects. Softcover, 8-1/2x11, 160 pages.
New Product: Pinstripping Masters 2, same size and format as original "Pinstripping Masters" but with new strippers.
Series PM & PM2

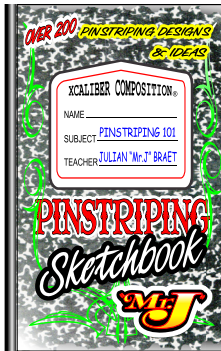

PINSTRIPPING SKETCHBOOK
Contains over 200 handdrawn pinstripping ideas & sketches.
30 pages, 5 by 7 in. **Series XP101**



MORE SIGNS, GRAPHICS, & STUFF
Logos and sign sketches, plus great insight into Gary Anderson's approach to design. **Series MSGONS**



GOLD LEAF TECHNIQUES **Series GLT**
Revised by Kent Smith
This thorough sourcebook details the art of gilding with step-by-step instructions and profuse illustrations, covering both the basics of handling gold leaf as well as advanced techniques and applications. It carefully explains the basic procedures for creating gold leaf window signs - from layout, pounce patterns and gilding, to backing up, finishing and varnishing.



LOGO DESIGN FOR SMALL BUSINESS
by Dan Antonelli **Book One & Two**
Every creative sign maker has the potential to design—and sell—effective logos for the businesses they make signs for every day. Learn Dan Antonelli's straightforward approach to creating and marketing effective, appealing logos—and see over 120 full-color examples. Designing logos is more profitable than you think. **Series LP**



- Why designing a logo primarily for print usage may hurt your client.
- Why corporate logos may rely on safe typography and a simple graphic, yet many small businesses may be better served by a more colorful design.
- How your logo designs can make a small business look bigger—or like a franchise.
- When to use a horizontal or vertical format for a logo design.
- How to educate your small business clients about the power of their logo. **Series LP2**

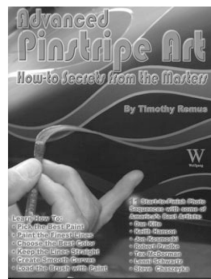

Advanced Pinstripe Art
by Timothy Remus
Series Book APA



MASTERING LAYOUT **Series ML**
by Mike Stevens
This best-selling book covers the fundamental principles of layout for signs. It teaches how to see, organize and manipulate graphic elements for unified, legible and visually appealing result. More than 80 illustrations demonstrate "before-and-after" results of applying the principles. Includes a troubleshooting checklist for isolating, analyzing and correcting layout weaknesses in your own designs.



Series 101
"101 PINSTRIPPING IDEAS" & "PINSTRIPPING BY ROTH"
Books written by "Big Daddy" Ed Roth.
Licensed to distribute by Andrew Mack.



2016 SIGN PRICING GUIDE
48 pages, 6 by 10 7/8 in.
Series SPG

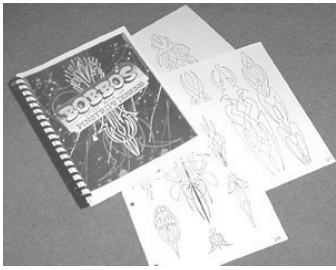

Here's an original from one of the original pinstripers
"BOBBO'S LITTLE BOOK OF PINSTRIPE DESIGNS"
 128 one-sided pages in an 8 1/2" x 11" format with many pages of pinstripe designs, scrolls and tribals printed on quality lazer paper and spiral bound to simplify coping. Being one of the original pinstripers and custom painters in the 50's and at the request of many pinstripers, he has put over 51 years of thought and design in this book. And some pages have multiple designs and many of the design are his famous one-line designs he calls 'ONE LINERS' (one continuous line). An exceptional aid for beginners and professionals who have imagination brain freeze and need an imagination boost!
SERIES BOBBO



Pinstriping Instruction & Designs
 By Todd Hanson

Filled with over 200 high quality hand-painted designs and color photos, Todd Hanson, with over 30 years experience and longtime contributor to SignCraft Magazine, writes a smart and easy to understand, informative approach to pinstriping. Divided into 3 sections, the instruction section offers insight into things such as, trimming a brush, mixing paint, and features a step by step on how to build a design. The instruction section focuses on design theory to help you gain the proper and necessary knowledge to build quality designs. The design section features 34 pages of hand-painted designs for practice and inspiration.

And finally the all-color photo section allows the reader to see finished pinstriping designs on various objects such as hot rods, trucks, motorcycles, gas pumps, and panels.
Series - Book-PI&D

MACK BRUSH REVIEW DVD
 Series #DVD-MACK

With an overwhelming variety of striping and lettering brushes available, the right choice for your specific application can be difficult and confusing (even for advanced artists!) In this DVD, pinstriping master Gary Jensen unlocks the mystery and confusion of striping, scrolling, and lettering brushes by demonstrating the use of each brush in the extensive Mack Brush Company line. In this DVD, you'll learn how to: Palette a brush, tell if your brush is overloaded, pull a straight and consistent line, trim a brush, achieve thin and thick lines, paint great designs, end a line anatomy of a brush, the various synthetic and natural brush hairs, outline flames and letters, hold a brush, make seamless line connections, why the differences in hair lengths, lettering quills, and flats, block, freehand, script, and casual lettering, perform teardrops, scrolls, and signatures, make a dagger stroke, wet-on-wet blending, anatomy of a sword striper, the numbering system of sword stripers, rudder action of a brush, clean and maintain your brushes, and more!

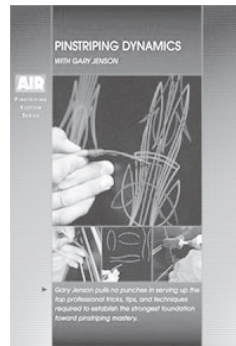

Pinstriping Dynamics (DVD)
 with Gary Jensen

Here's the ultimate guide for beginning to intermediate pinstripers and artists alike. Featuring Gary Jensen-one of the World's best-as your guide, this presentation pulls no punches in serving up the top professional tricks, tips, and techniques required to establish the strongest foundation toward pinstriping mastery. As a special added bonus, gold leaf pinstriping is included!

Series GJPD
 Available on DVD only. 53 minutes

Pinstriping Kustom Series from Air Brush Action

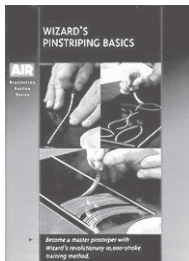

"Wizard's Pinstriping Basics"
 Become a master pinstriper with Wizard's revolutionary training method, VHS tape or DVD, same price
Series WZPB

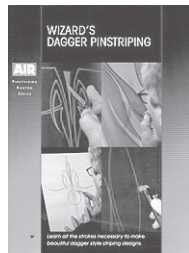

"Wizard's Dagger Pinstriping"
 Learn all the strokes necessary to make beautiful old school style striping designs, VHS tape or DVD, same price
Series WZDP

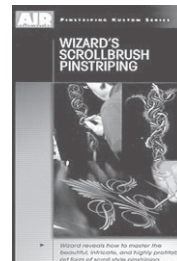

"Wizard's Scroll Brush Pinstriping"
 The Wizard reveals how to master the beautifully intricate & highly profitable art form of scroll style pinstriping, VHS tape or DVD, same price
Series WZSBP

LEARN PINSTRIPING For Fun and Profit

Presented by masters of the art with 30-years combined experience is a step-by-step instructional videotape . . . complete with practice patterns of the simple basic strokes from which all professional pinstriping is derived.
Series PME

"Pinstriping Made Easy" DVD ONLY!
 YOU WILL RECEIVE

- Over 45 minutes of instructional information
- Tips on paints, brushes, techniques

NOTE: All DVDs are non-refundable.

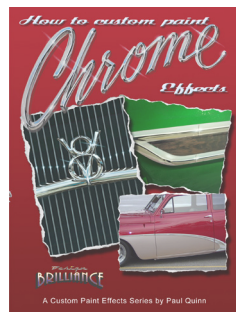
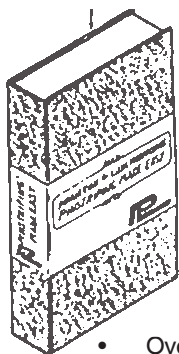

"How to Custom Paint Chrome Effects"

by Paul Quinn — Nationally known airbrush and pinstriping artist and instructor, Paul Quinn, owner of Design Brilliance LLC, announces the release of a new instructional DVD 'How to Custom Paint Chrome Effects'. Paul walks you through the process of painting a dimensional faux chrome molding and its practical application on a vehicle. You'll learn the products, tools and techniques needed to create this stunning effect.
Series DVD-CE

M/T-H000 Mack Tidwell Triple Hippie



The long awaited follow up to his sold out 'SQUATCH WHISKERS 000 striping brushes. The HIPPIE TRIPLE is a 000 size brush with full length hair. These bad boys handle like a sports car and carry enough paint to actually get some lines thrown down without having to re-load. This is a real striping brush that happens to make really fine lines.

Series M/T-H000



Wizard's Pinstriping Masters Dagger

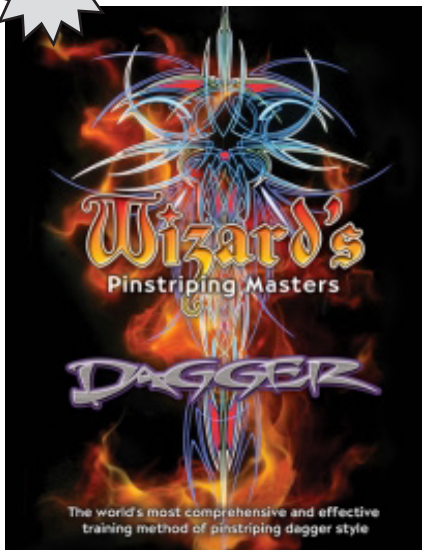

Dagger style pinstriping is the a beautiful way to enhance any vehicle. It is the most popular and most profitable thing I've done for the past 45 years. However, symmetry, design capability and line quality are the three elements that most often elude the beginner and veteran alike. How do you stay consistent, sharp, and imaginative in your work? How do you find new directions to take your work? I have revealed my "PRACTICE FACTORY" method that I still use to keep sharp. I also show how to practice and work THROUGH difficult distractions- situations that will stop a pinstriper in his tracks. This video shows how to raise the bar and learn the secrets of pinstriping masters- secrets that I have collected in my long, wonderful and successful career.

I welcome you into my shop and into my "head" as I share personal secrets, thought processes, and maneuvers that I have developed and learned from other masters. You will enjoy this video every time you view it, and your growth will be apparent immediately as you make progress faster than ever before.

Series DVD-WPMD



Wizard's Pinstriping Masters Scroll



Scroll style pinstriping is the most elegant, yet difficult style to master. I have seen many failed attempts at this elusive style, and sympathize with anyone who has picked up a scroll brush and "gave it a whirl".

The instruction contained in this video is a result of 45 years of experimentation and perfection of the scroll style. I will show you, through a 2-part instructional session the secrets I have learned and the shortcuts to pinstriping mastery. You CANNOT learn the scroll style by picking up a brush and expecting magic to happen. There are principles and movements necessary to execute good scroll designs. If you have tried and failed, this video is for you.

If you have been trying to design scroll styles, but only end up frustrated, this method can help you. Tired of copying someone else's style? This video is for you.

Learn to scroll like a master - have the confidence that every time you pick up the brush, you will design beautiful scroll style pinstriping every time.

Series DVD-WPMS

Domini-Quinn Striper NEW



The new Domini-Quinn striping brush takes its cues from the legendary, "Dominican," arguably one of the finest brushes to ever lay a line. Mack Brush has teamed up with Paul Quinn to recreate this brush of legend! From the length of the hair to its ultra thin ferrule, this brush pulls lines with the precision of a razors edge!

Series - QM-D

Size	00	0	1
------	----	---	---

Hot Rod Surf Pinstriping Brush NEW



Our company has teamed up with HOT ROD SURF founder and artist Mark Whitney Mehran (MWM) to produce a specialized pinstriping brush for traditional freehand hot rod & motorcycle pinstriping.

Series HRS-1

This brush is a faithful reproduction of the modified pinstriping brush that MWM uses in the Hot Rod Surf Pinstriping Techniques Movie and his book Basic Hot Rod Pinstriping Techniques with Hot Rod Surf.

The Hot Rod Surf MWM series pinstriping brush is a multi-functional brush that is great for the 1950's style freehand pinstriping and rugged enough to be put into daily professional use.

The HRS-1 brush is specially designed to do it all from thick lines to thin lines, straight lines to circles, and everything in between.

- ◆ This brush was manufactured with the beginner in mind and has the quality for the seasoned vets.
- ◆ The brush is made with the classic dowel handle and the hair that is used is European dressed blue squirrel hair.

We are excited to bring such an expensive haired brush to the striper at an affordable price.

1111 Mack Long Stryper NEW



"Once upon a time in Michigan, Texas, and California, lived a lazy pinstriper. He wanted to make a lot of money fast.

This pinstriper was busy with dealer lots, asphalt, dirt, and gravel. He pinstriped 20-30 cars per day in sun, rain, and wind. He started with a Grumbacher 1010, but when the wind blew, the little brush was taken by the wind. He wanted a brush the wind would not bother.

He called Grumbacher and they made him a brush with taklon bristles. All was well, but the lazy pinstriper was still not happy. He now wanted to pull longer lines. He called Grumbacher again, but they sent him too short of a brush. He was told they had been conquered by the evil Kohinoors. The lazy pinstriper contacted the Maine Brush Company, but the Maine Brush Company was also conquered. The search continued for the magic bristle, leading the lazy pinstriper to the Andrew Mack & Son's Brush Company.

Other brush makers suggested a blend of natural and synthetic bristles. The blend was highly sought after, a rare commodity, and soon to be extinct.

He called Chris at Andrew Mack & Son Brush Company and cried, "Woe is me! These other nitwits forgot the formula and can't find the hair (or their ferrules either)." The mighty Chris said, "Have no fear, I have an idea! There is a new taklon and we can do it!"

After much trial, the Longstriper 1111 was created, the homage to the Grumbacher 1010 as per Spinal Tap where their amps went to 11. If you do commercial work, you are going to love these. This is the best straight line brush I have ever used. Moisture has no effect on this brush and a 20mph wind is no match for this brush."

-Michael Menard

Series-1111

Size	00	0	1
------	----	---	---

DC Micro Mono by DeWayne Connot



After using synthetic brushes, one might wonder if a natural haired brush could compare and perform. The Mack Brush Company did just that by creating the new Micro Mono brush. It's a natural, soft haired brush with just the right snap! Doing small letters will never be easier when you use this brush. Made with 100% blue squirrel hair. **Blunt End**

DC - MM - Set →
Series - DC-MM

Size	3/0	2/0	0	1	2

DC Micro Script by DeWayne Connot



Synthetic detail brushes are no comparison to the natural hair and pointed detail brush of the new Micro Script brush. You will get the finest little lines and delicate touches you didn't even believe were possible. It is the brush you will fall in love with for all the little things you do. Made with 100% blue squirrel hair. **Pointed End**

DC - MS - Set →
Series - DC-MS

Size	3/0	2/0	0	1	2

Drag'N Fly by Ted Turner



A soft and snappy full synthetic (Teijin) long liner. Primarily intended for my own style of lettering, pictorials and pinstriping. This brush set flat-out performs superb for small lettering, script, outlining text and images.

Create intricate design work with a brush that can get in the tight spaces and keep your line work as fine as possible. Works perfect with enamels, inks, urethanes, and water based colors.

(adjust viscosity accordingly)

Series DF - (size)

Size	Full Set	000	00	0	1	2	3	4	5

RP-8 Gilders Dusting Oval Mops



Gold Leaf Dusting Mop Brush size 1-1/2", are used to gently Dust away the excess gold leaf known as Skewings. Remember to dust gently, because the excess gold that you dusting off, can scratch the gold on the surface. Gold Leaf Dusting Mop Brushes, are also used for applying fine Mica or Bronzing Powders over gold size (gold leaf application varnish), simply dip the Dusting Mop into your powder and the transfer to the gold size gently, if you get any hairs stuck in the gold size, simply lift out and continue to cover or flock the surface. Made with premium goat hair.

Series RP-8

Size	RP 8-10	RP 8-14	RP 8-18	RP 8-20	RP 8-24

CARDED BRUSHES

**DYNASTY
SET NO. 7**



Contains:
Nos. 3/0, 2/0, 0, 1
Fine Detail

**DYNASTY
SET NO. 5**

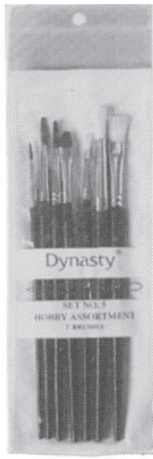

Contains:
7 Assorted
Brushes

**DYNASTY
SET NO. 6**



Contains:
Nos. 2, 4, 6, 8
White Bristle Rounds

**DYNASTY
SET NO. 21**

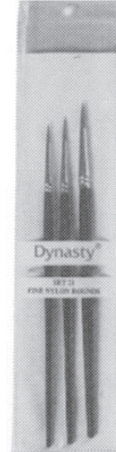

Contains:
Nos. 1, 3, 5
Fine Nylon Rounds

**SERIES
A555**



Contains:
Nos. 2, 4, 6

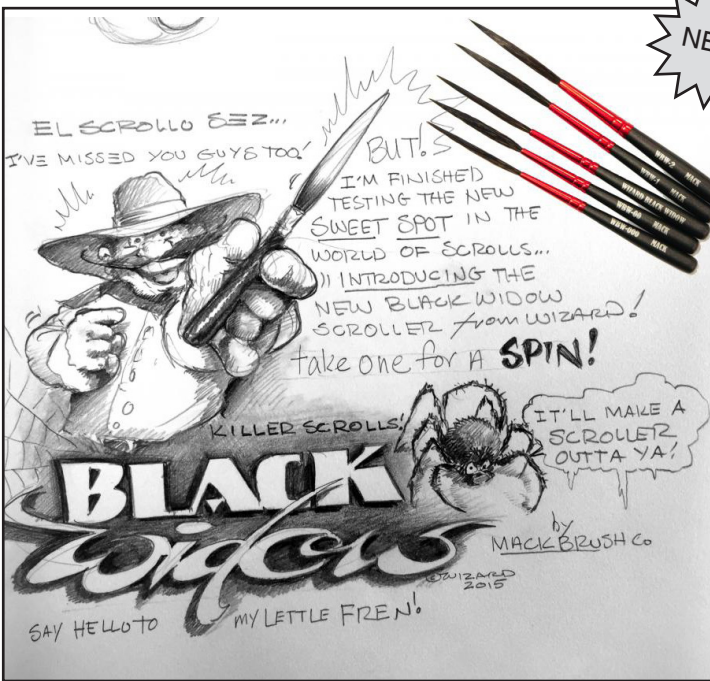

Mack's New Black Widow Scroller

Series #WBW

The Wizard Black Widow is the latest scrolling brush from Mack Brush and Steve "The Wizard" Chaszeyka. Developed for maximum control and response, to the specs of a veteran scroll striper, it holds the line and delivers beautiful results. If you use scroll striping, you'll love this brush!

Size	000	00	0	1	2

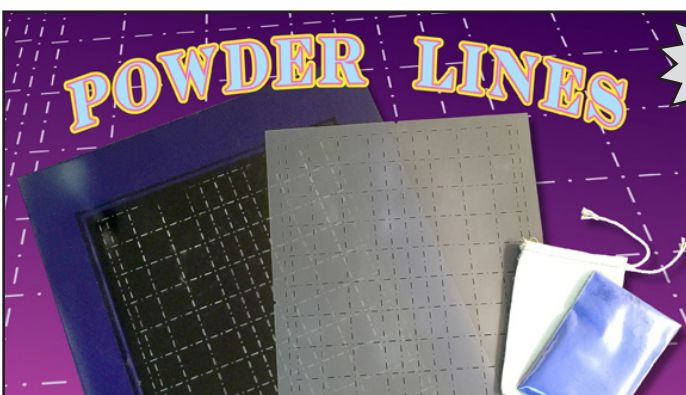

Powder Lines

Series #PL

The "Working" layout grid

Fast, easy and precise design layout. No leftover tape or pencil residue. Use it on curved surfaces **ON THE JOB** clean, and quick removal.



*When drawing stripes, both broad and fine and what is more a double line
You're never safe from a man's attack, unless your stripers come from Mack.*

- D. Mack T-Shirt
 Sizes come in
 M,L,XL,XXL, 3XL
 Series T-WIZARD



Since 1891
www.mack-brush.com



Large Crest Logo
 in Front and
 Small Logo
 across the back
 of the T-Shirt

Shirts available in
 Grey or White
 Sizes M, L, XL, XXL

SERIES T-LOGO

Two Logo Colors
 Available

- 1. Purple/Navy/Yellow
- 2. Navy/Red/Yellow



SERIES T-LOGO



Jeral Tidwell
 Pinstriped
 Fist Design T-Shirt.
 Available in Black
 Sizes M, L, XL, XXL,
 XXXL

Drew Mack Blue
 T-Shirt Design.
 Available in White
 Limited Sizes Available

SERIES T-HANSON

Our hats and T-shirts continuously change in design and color.

*If you are interested in purchasing a hat or T-shirt,
 call for current designs and colors available.*

- E. Adjustable Hat with multi-color embroidered logo.
 Approximately 7897 stitches. Available in many colors
 Hats available in Coaches style or low-Profile.



The Mack Collection

Our Collection Includes:

- A. Earrings
- B. Small Brush Pendant with bale
- C. Shop Apron with Mack Logo
- D. T-Shirts - 50/50 Premium
- E. Adjustable Hats
- F. Scully Cap



B B A
 WITH CHAIN

- A. 14K gold sword striper earrings with 14K gold loops for pierced ears. Pennyweight = .65
- B. 14K gold sword striper pendant with bale. The bale allows the pendant to hang from a rope necklace. Penny weight = 1.60. Approximate length 1 5/8"

Please Note:

All of our Jewelry will soon be available in Sterling Silver. Call for pricing.

The Pendants are made to hand on a rope necklace (rope necklace not included)

- C.



- F.



THE MACK STORY

FOUNDED 1891



Old cut of a Mack Double Thick Square-End Stripper



Old cut of a Mack Dagger Stripper

Although the Andrew Mack and Son Brush Co. was founded in 1891, its history goes back to 1865. It was during that year that J.J. Deal founded his wagon and buggy factory in the small village of Jonesville, Michigan. The Deal factory quickly gained the reputation of building the finest carts, wagons and carriages in the Midwest. The products were first class in every detail—even the paint!



Andrew Mack
Founder
1860-1946

It was with this emphasis on quality that the Mack Company made its contribution for several years prior to 1891. Andrew Mack (1860-1946) had been the head stripper at the Deal Co. Andrew was a true perfectionist and he had never been completely happy with the quality and performance of the striping brush furnished him by the Deal Co.



Andrew Mack
Founder
1860-1946

Andrew Mack

Original Signature



Today's Trademark



Original Trademark
Founded in 1891

Through months, and probably years, of experimentation with various brushes, Andrew finally developed what is now known as the "Mack Striping Pencil." All carriages carried a great deal of pin striping during this period of our country's history. It wasn't long before other companies and pin strippers throughout the United States heard about Andrew's improved striping brush and wanted to secure a few brushes for their own striping needs.

Soon the demand for Mr. Mack's brushes was so great that it was time to strike out on his own and enter into the manufacture of striping brushes. Andrew Mack resigned from the Deal factory in 1891 and was destined to originate one of the most unique manufacturing companies in the world.



JONESVILLE, MICHIGAN
Original Logo

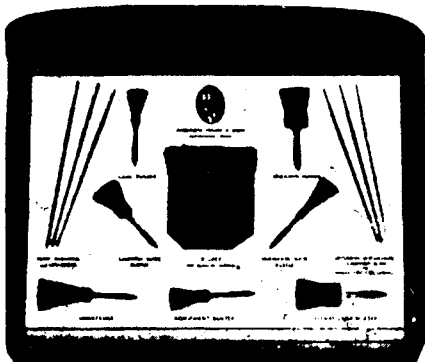

Page from an old Andrew Mack catalog

Since Andrew Mack died in 1946 (at the age of 86), the early history of his company is very sketchy at best. We know that he operated his company out of several buildings and homes prior to his death. We understand that in the 1930's there were over 30 ladies working for him full time manufacturing just the pin striping brush. Of course, one must remember that this was the hey-day of pin striping (no tape, rollers, spray or air brush guns, were on the market at that time).

Andrew's son, Glenwood, was involved in the family business on and off from 1911 until he took over full ownership in 1946 after Andrew's death.

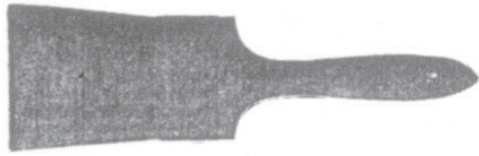

Dusters for Photographic Lens
(Cataloged and sold until about 1955)

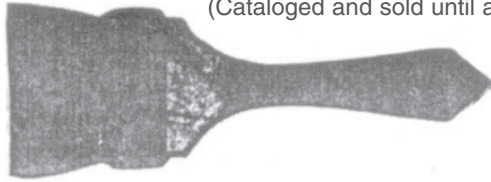

TESTIMONIALS

(Taken from an old Andrew Mack catalog.)

Mr. Andrew Mack, Jonesville, Mich.

My Dear Sir: — We are very pleased to add our testimonial to a number which we presume you have, as your goods have proven very satisfactory, and we have used them for the past four years.

We assure you that as long as the quality you are giving us at the present time is maintained we shall not look around very much for sword stripers.

B. Rosenweig, Jr., Purchasing Agent
BUICK MOTOR COMPANY

Flint, Mich.

.....

Toledo, Ohio

Andrew Mack, Jonesville, Mich.

Dear Sir: — Your favor of the 12th at hand. We wish to state that your stripers have been well adapted to our requirements and we have found them in all ways entirely satisfactory.

THE TOLEDO METAL WHEEL CO.

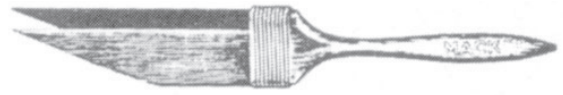

Old cut of a Mack Double Line Striper
Sold until about 1960

From 1946 until 1961 were the years of experimentation for the Mack Company. Glenwood spent countless hours in quality control and time studies. He entered the photographic market with a brush that was used in cleaning camera lenses. He contracted artist and signwriter brushes from a company in New York called "Art & Sign". He developed this art and signwriter business until it accounted for about 25% of the overall sales. However, by 1961 Glenwood was 72 years old and it was time to step down and enjoy life.

Jon M. (Mike) Fast, a friend of the Mack family, purchased the business in 1961. He was a junior at the University of Michigan Business School at the time, and has continued as the president of the business to the present date. His son, Jonathan Christian "Chris" Fast, is in the process of buying the company. Mike and wife Betty remain active but are semi-retired. They are extremely pleased that Andrew Mack will stay in the family. Chris is doing a fantastic job!

Sales, through inflation and growth, have increased many times over the last thirty plus years, and the Andrew Mack and Son Co. is more viable and diversified than at any other time in its history. The Company continues as the world leader in quality pin striping and touch up brushes, but they have also branched out into many other allied areas.

The following poem was also taken from an old Andrew Mack catalog.

When drawing stripes both broad and fine
And what is more a Double Line,
You're never safe from man's attack
Unless your Stripers come from "Mack."

The Pin Striping Brush that is manufactured today is essentially the same brush that Andrew Mack first made in 1891, (although many of the leading stripers in the world would give anything to get hold of one of those "Old Mack brushes"). The pin striping brush is totally a hand-crafted operation, just as it was in 1891. There is not one piece of machinery used in its manufacture. It is completely manufactured in Jonesville, Michigan, by eight to ten very talented technicians. The squirrel hair comes from the cold regions of the Soviet Union and China. Many attempts have been made to raise squirrels or use the tails from Northern Canada, but the quality just isn't there! By the way, our brush as well as many other artist and signwriter brushes, has always been labeled "Camel Hair". This couldn't be farther from the truth. There is no such thing as "Camel Hair". It was a name given squirrel and other soft animal hair a long time ago and most of us have been afraid to drop the label for fear of losing you as a satisfied customer.

The hair that we use in our striping brushes is 100% unmixed squirrel hair and the brush is made in America by Americans. This is a statement that no other pin striping manufacturer can claim.

The Andrew Mack Brush Company is rich in history and pride. We are the originators of the Pinstriping Brush, and we feel that we still give you the very best brush in the world.

I am sure Mr. Andrew Mack would be proud of his company today. We have had great, dedicated employees through the years. It has been a challenge to develop new products and ideas these past thirty-four years. We have all enjoyed a fantastic relationship with you - "THE BEST CUSTOMERS EVER!"

You Can Do It With A



Striper

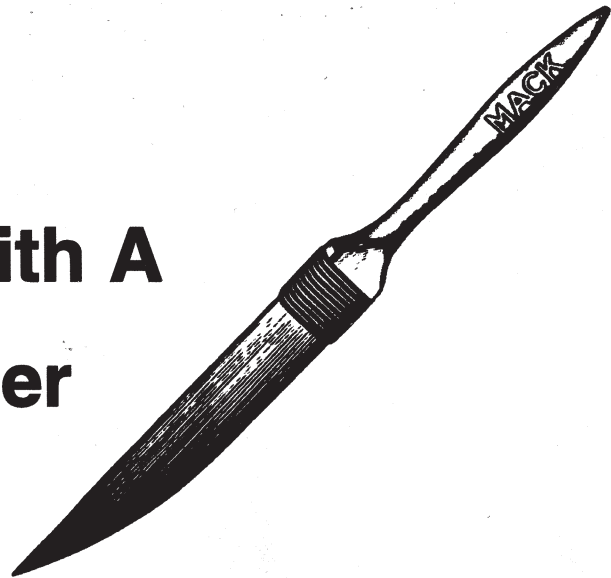

HERE ARE SOME OF THE PRODUCTS AND USES THAT "MACK STRIPERS"
HAVE SERVED
AND THE LIST CONTINUES TO GROW EACH YEAR:

Agricultural Machinery
Airplanes
Antiques
Arrows
Art Work
Automobiles
Beds
Bicycles
Buggies
Business Machines
Buses
Carriages
Ceramics
Chinaware
Coaches
Electrical Equipment
Engines
Farm Implements
Filing Cabinets
Fingerprinting

Fire-fighting Equipment
Food Machinery
Furniture
Garden Equipment
Glass and Glassware
Gliders
Hardware
Lawn Mowers
Lettering
Metalware
Mill Machinery
Motorcycles
Office Equipment
Photography
Picture Frames
Radios
Railroad Equipment
Refrigerators
Rubber Goods
Safes

Scales
Show Cards
Sign Writing
Scooters
Sleds
Sporting Goods
Spraying Equipment
Stage Scenery
Street Cars
Sulkies
Tools
Toys
Trucks
TV Cabinets
Typewriters
Velocipedes
Wagons
Laundry Machinery
Washing Machines
Windmills

